

# Temperature Prothermo NMT 538

## Operating Manual

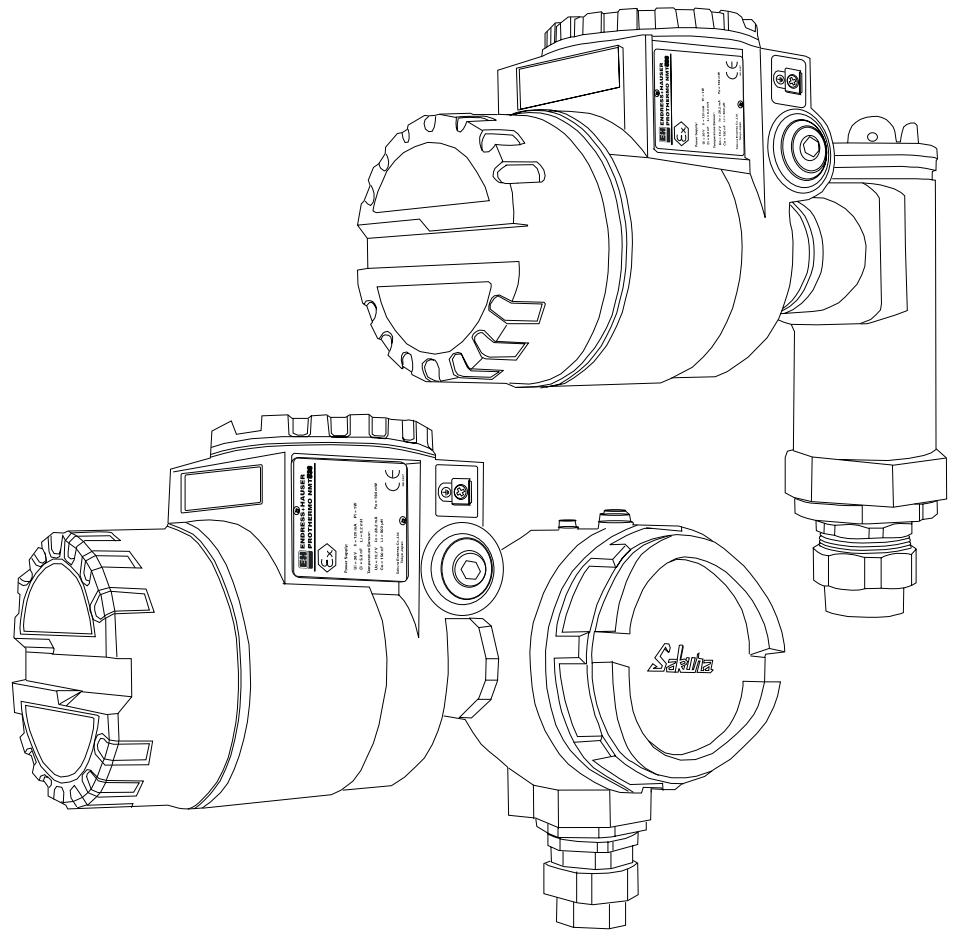

## Table of Contents

### General notes ..... 3

### Safety instructions ..... 4

- 1.1 Designated use ..... 4
- 1.2 Installation, commissioning and operation ..... 4
- 1.3 Operation safety ..... 4
- 1.4 Return ..... 4
- 1.5 Notes on safety conventions and symbols ..... 5

### Safety instructions ..... 6

- 2.1 Device designation ..... 6
  - 2.1.1 Nameplate ..... 6
  - 2.1.2 Ordering structure ..... 7
  - 2.1.3 Specifications ..... 8

### Installation ..... 9

- 3.1 Incoming acceptance, transport, storage ..... 9
  - 3.1.1 Incoming acceptance ..... 9
  - 3.1.2 Transport ..... 9
  - 3.1.3 Storage ..... 9
- 3.2 Installation conditions ..... 10
  - 3.2.1 Dimensions ..... 10
- 3.3 Mounting ..... 11
  - 3.3.1 Mechanical connection ..... 11
  - 3.3.2 Wiring: NMT538 to RTD probe ..... 13
- 3.4 HART line cabling ..... 18
  - 3.4.1 Protection from line noise ..... 18
  - 3.4.2 Connection to the Proservo NMS53x ..... 19
  - 3.4.3 Connection to the Tank side monitor NRF590 ..... 20

### Operation Principle ..... 21

- 4.1 High Accuracy Converter ..... 21
- 4.2 Temperature calculation ..... 22
  - 4.2.1 Calculation of average temperature in the liquid layer ..... 22
  - 4.2.2 Calculation of average temperature in the liquid gas / vapor layer ..... 22

### Operation Principle ..... 23

- 5.1 NMT538 operation with the Proservo NMS53x ..... 23
  - 5.1.1 Home position display ..... 23
  - 5.1.2 Optical key (touch control) operation ..... 23
  - 5.1.3 Access code ..... 24
  - 5.1.4 Type of the Programming Matrix group ..... 25
  - 5.1.5 Configuring the NMT538 on the matrix of Proservo NMS53x ..... 26
  - 5.1.6 Setting parameter on the matrix ..... 27
  - 5.1.7 Additional parameter setting functions ..... 30
- 5.2 The Proservo NMS53x matrix (NMT538 related matrix only) ..... 31
- 5.3 Description of the programming matrix ..... 35

### Operation with the Tank Side Monitor NMF 590 ..... 40

- 6.1 Initial NMT538 configuration before connect to NRF590 ..... 39
- 6.2 Additional adjustment factors ..... 39
- 6.3 NMT538 operation from NR ..... 39

### Configuration from ToF (Time of Flight) tool ..... 41

### Error code ..... 42

### Appendix ..... 44

---

## General notes

### Instruction manual

- This instruction manual applies to the NMT538 with V.6x software installed.
- Please read this manual carefully and make sure you understand its contents before using the product.
- This manual is solely intended to describe product functions and should not be used for any other purpose.
- No part of this manual may be reproduced or reprinted without permission.
- This manual may be subject to change without prior notice.
- This manual was prepared with the highest degree of care. However, should you find any errors or have any questions, contact one of our service offices or your local sales agent.

### Product Requirements

#### Power source

Check the voltage of the power supply before connecting it to the product. It should be the exact voltage required for proper operation of the product.

#### Use in hazardous areas

When using the product in a first or second-class hazard location (Zone 1 or Zone 2) be sure to use an intrinsically safe or pressure- and explosion-proof apparatus. Take the utmost care during the installation, wiring, and piping of such an apparatus to ensure the safety of the system. For safety reasons, maintenance or repairs on the product while it is being used with such an apparatus should only be performed by qualified personnel.

#### External connection

When an external connection is required, the product should be protectively grounded before it is connected to a measurement object or an external control circuit.

# 1 Safety instructions

## 1.1 Designated use

The Prothermo NMT538 temperature signal converter is designed to be connected to RTD type Intrinsically safe average temperature probe. Use for purpose other than originally intended may cause failure. Failure may occur if the inappropriate probe is connected or as a result of improper operation. Carefully read this instruction manual before attempting to use the NMT538 and connection to the desired temperature probe.



Caution!

### Caution!

Before opening the cover of the Prothermo NMT538 for maintenance, switch off the power supply of the Proservo NMS53x or the Tank side monitor NRF590. Either of described instruments are the host gauge for supplying DC voltage on the HART line.

## 1.2 Installation, commissioning and operation

- Mounting, electrical installation, start-up and maintenance of the instrument may only be carried out by trained personnel authorized by the operator of the facility.
- Personnel must absolutely and without fail read and understand this Operating Manual before carrying out its instructions.
- The instrument may only be operated by personnel who are authorized and trained by the operator of the facility. All instructions in this Manual are to be observed without fail.
- The installer has to make sure that the measuring system is correctly wired according to the wiring diagrams. The measuring system is to be grounded.
- Please observe all provisions valid for your country and pertaining to the opening and repairing of electrical devices.

## 1.3 Operational safety

### Hazardous areas

Measuring systems for use in hazardous environments are accompanied by separate "Ex documentation", which is an *integral part* of this Operating Manual. Strict compliance with the installation instructions and ratings as stated in this supplementary documentation is mandatory.

- Ensure that all personnel are suitably qualified.
- Observe the specifications in the certificate as well as national and local regulations.

### Fcc approval

This device complies with part 15 of the FCC Rules. Operation is subject to the following two conditions: (1) This device may not cause harmful interference, and (2) this device must accept any interference received, including interference that may cause undesired operation.



Caution!

### Caution!

Changes or modifications not expressly approved by the party responsible for compliance could void the user's authority to operate the equipment.

## 1.4 Return

The following procedure must be carried out before a transmitter is sent to Endress+Hauser for repair.

- Always enclose a duly completed "Hazardous Substance Data sheet" form. Only then can Endress+Hauser transport, examine and repair a returned device.
- Enclose special handling instructions if necessary, for example a safety data sheet as per EN 91 / 155 / EEC.
- Remove all residue which may be present. Pay special attention to the gasket grooves and crevices where fluid may be present. This is especially important if the fluid is dangerous to health, e.g. corrosive, poisonous, carcinogenic, radioactive, etc.



Note!

### Note!

A copy of the "Hazardous Substance Data sheet" is included at the end this operating manual.



**Caution!**

- No instrument should be sent back for repair without all dangerous material being completely removed first, e.g. in scratches or diffused through plastic.
- Incomplete cleaning of the instrument may result in waste disposal or cause harm to personnel (burns, etc.). Any costs arising from this will be charged to the operator of the instruments.

## 1.5 Notes on safety conventions and symbols

In order to highlight safety-relevant or alternative operating procedures in the manual, the following conventions have been used, each indicated by a corresponding symbol in the margin. Protection from line noise.





### Safety conventions

Symbol	Meaning
	<b>Warning</b> A warning highlights actions or procedures which, if not performed correctly, will lead to personal injury, a safety hazard or destruction of the instrument.
	<b>Caution!</b> Caution highlights actions or procedures which, if not performed correctly, may lead to personal injury or incorrect functioning of the instruments.
	<b>Note!</b> A note highlights actions or procedures which, if not performed correctly, may indirectly affect operation or may lead to an instrument response which is not planned.

### Explosion protection

	<b>Device certified for use in explosion hazardous area</b> If the Micropilot has this symbol embossed on its name plate it can be installed in an explosion hazardous area.
	<b>Explosion hazardous area</b> Symbol used in drawings to indicate explosion hazardous area. - Devices located in and wiring entering areas with the designation "explosion hazardous areas" must conform with the stated type of protection.
	<b>Safe area (non-explosion hazardous area)</b> Symbol used in drawings to indicate, if necessary, non-explosion hazardous areas. - Devices located in safe areas still require a certificate if their outputs run into explosion hazardous areas.

### Electrical Symbols

	<b>Direct voltage</b> A terminal to which or from which a direct current or voltage may be applied or supplied
	<b>Alternating voltage</b> A terminal to which or from which an alternating (sine-wave) current or voltage may be applied or supplied
	<b>Grounded terminal</b> A grounded terminal, which as far as the operator is concerned, is already grounded by means of an earth grounding system.
	<b>Protective grounded (earth) terminal</b> A terminal which must be connected to earth ground prior to making any other connection to the equipment.
	<b>Equipotential connection (earth bonding)</b> A connection made to the plant grounding system which may be of type e.g. neutral star or equipotential line according to national or company practice

## 2 Identification

### 2.1 Device designation

#### 2.1.1 Nameplate

The follow technical data are given on the instrument nameplate:

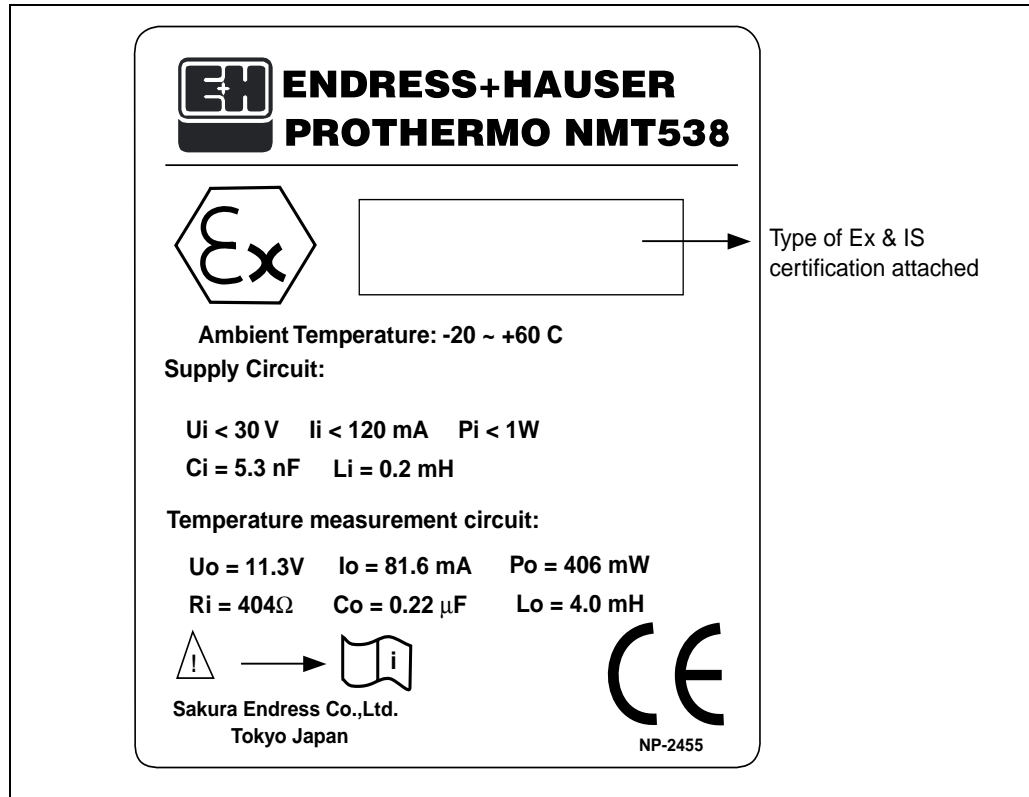

**2.1.2 Ordering structure**

<b>10</b>	<b>Protection class</b>			
	0	Protection: Weather proof IP 54		
	2	<del>EEx ia IIB T4, CENELEC</del> ...obsolete, Nov. 2002		
	3	EEx ia IIB T4, ATEX		
	7	IS Class 1, Div 1, Gp, CD, FM		
	8	Class 1, Div 1, Gp, CD, CSA(Exi).....pending		
	9	Special version		
<b>20</b>	<b>Cable Entry</b>			
	A	One G(PF) 1/2" thread		
	B	One NPT 1/2" thread		
	C	One PG 16 Thread		
	D	One M 20 thread		
	Y	Special version		
<b>30</b>	<b>Process connection, material</b>			
	1	3/4" NPS, Galvanized. mild steel		
	2	M20, Varec 1700 probe connection only, mild steel		
	9	Special version		
<b>40</b>	<b>Measuring range</b>			
	1	Range: -50.....+200 °C (-58°F.....+392°F) liquid/gas temp. only		
	2	Range: -50.....+200 °C (-58°F.....+392°F) liquid/gas temp. and WB		
	9	Special version		
<b>50</b>	<b>Compatible Element Type</b>			
	0	Cu90, multi resistance element		
	1	CuPt100, multi resistance element		
	2	Cu90, multi spot element		
	3	Pt100, multi spot element		
	4	Cu100, multi resistance element		
	5	Cu100, multi spot element		
	9	Special version		
<b>NMT538-</b>				Complete product designation

### 2.1.3 Specifications

Accuracy of conversion	±0.15 °C
Number of connectable elements	2...16
Conversion temp. range	-50...+200 °C
Data communication	Multidrop HART Protocol Polling address: 02 for connecting to Proservo NMS 53x or Tank Side Monitor NRF590 (factory default value)
Input	Level data, operation, & configuration command from the NMS 53x Proservo or Tank Side Monitor NRF 590
Output	Liquid level regarded various temp. data & element information
Materials	Housing: Aluminium diecast Process connection: Galvanized carbon steel
Power supply	DC24V ±10% from Proservo NMS 53x IS HART line DC17 ± 1V from NRF 590 IS HART line Power supply range: Requires DC16-30V for normal operation condition
Current consumption	9mA ±0.5mA for signal pulse reception
Cable entry	G (PF) ½ x 1 NPT ½ x 1 PG 16 x 1 M20 x 1
Ambient temp.	-20...+60 °C (W. heating jacket option: -40...+60)
Certification	Weather proof IP54 <del>EEx ia IIB T4, CENELEC...</del> obsolete EEx ia IIB T4, ATEX IS class 1, Div 1, Gp.CD, FM Class 1, Div 1, Gp.CD, CSA...pending



## 3 Installation

### 3.1 Incoming acceptance, transport, storage

#### 3.1.1 Incoming acceptance

Check the packing and contents for any signs of damage.

Check the shipment, make sure nothing is missing and that the scope of supply matches your order.

#### 3.1.2 Transport



Caution!

#### **Caution!**

Follow the safety instructions and transport conditions for instruments of more than 4kg. Do not lift the measuring instrument by its housing in order to transport it.

#### 3.1.3 Storage

Pack the measuring instrument so that is protected against impacts for storage and transport. The original packing material provides the optimum protection for this.

The permissible storage temperature is  $-20^{\circ}\text{C} \dots +60^{\circ}\text{C}$  ( $-4^{\circ}\text{F} \dots +140^{\circ}\text{F}$ )

## 3.2 Installation conditions

### 3.2.1 Dimensions

Figure1: Dimension & appearance of temperature version housing

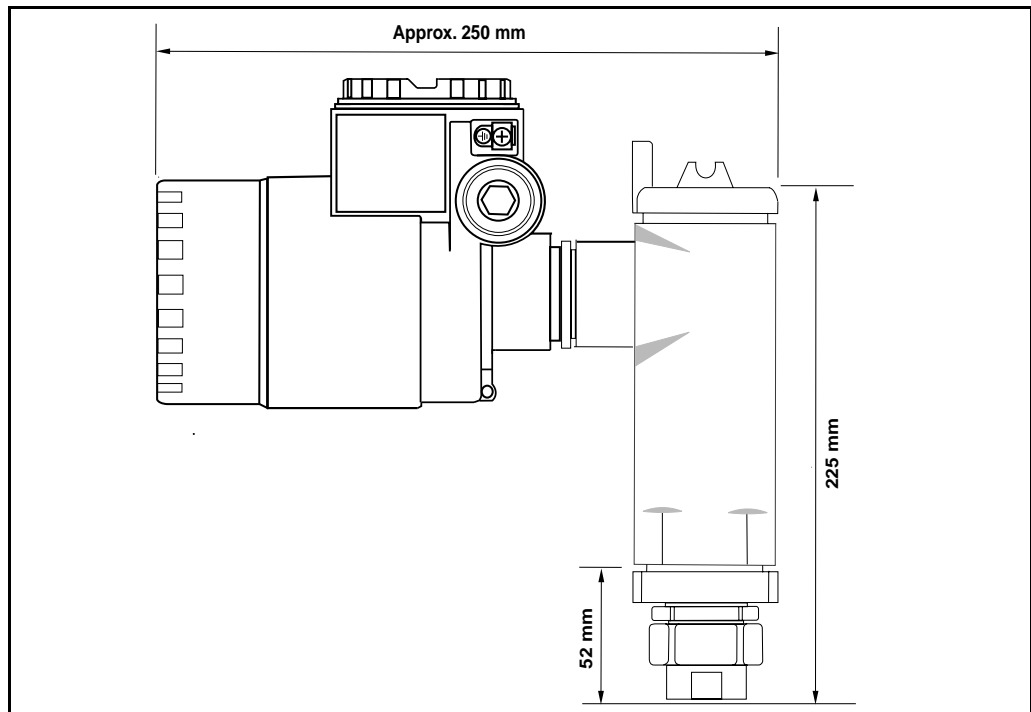
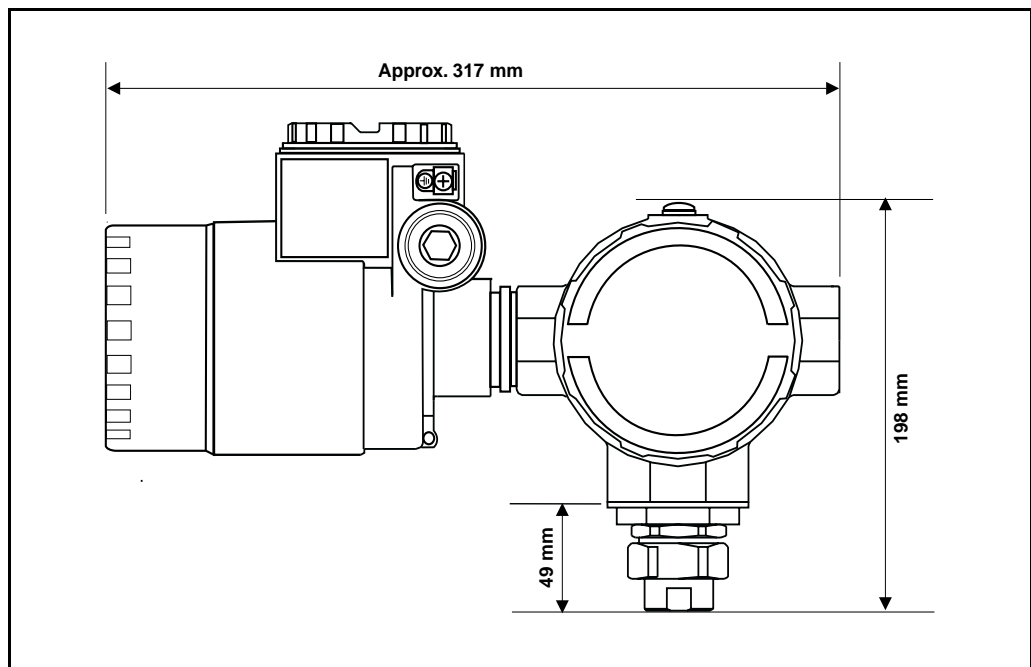
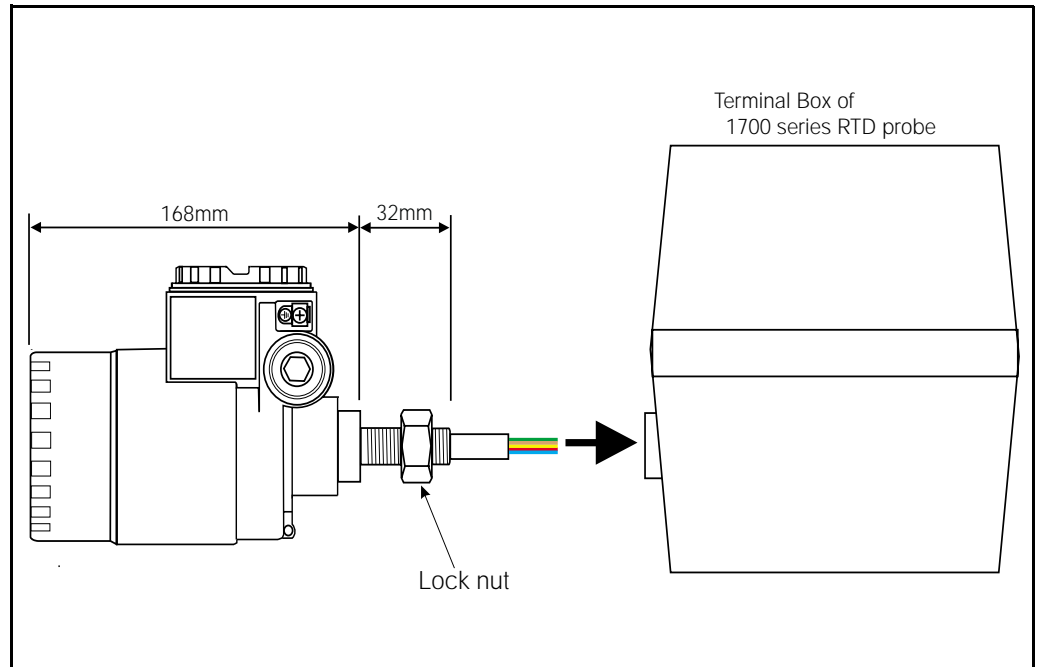

Figure2: Dimension & appearance of temperature and WB version housing



**Figure3: Dimension & appearance of UK Special version (connection to 1700 series average RTD probe only)**



Note!

**Note!**

UK Special is only designed to connect with Whessoe Varec 1700 series average temperature probe. WB data accessibility is no longer available at the NMT 538 prothermo.

**Mounting of UK Special version M20 connection to Varec 1700 terminal box**

Use seal tape on the threaded gauge to terminal box connection. Slip in a bunch of cable (RTD signal inlet cable) into the terminal box female thread connection. Turn the entire NMT 538 gauge head clockwise and screw in the connection at least 10 complete turns, then secure with lock nut against terminal box.



Note!

### 3.3 Mounting

#### 3.3.1 Mechanical connection

**Note!**

Prior to the removal of existing RTD temp. converter, note following information, also these information are applicable for new installations as well.

1. Element type (material & structure)
2. Total element number
3. Presence of bottom & vapor spot elements
4. Lowest element position
5. Elements intervals
6. Cable color for each element

Prior to perform NMT538 installation, temporarily tie up all RTD cables (and coaxial cable if the probe is equipped with Water Bottom sensor) with zip tight or short string to avoid damaging cables during mechanical connection.

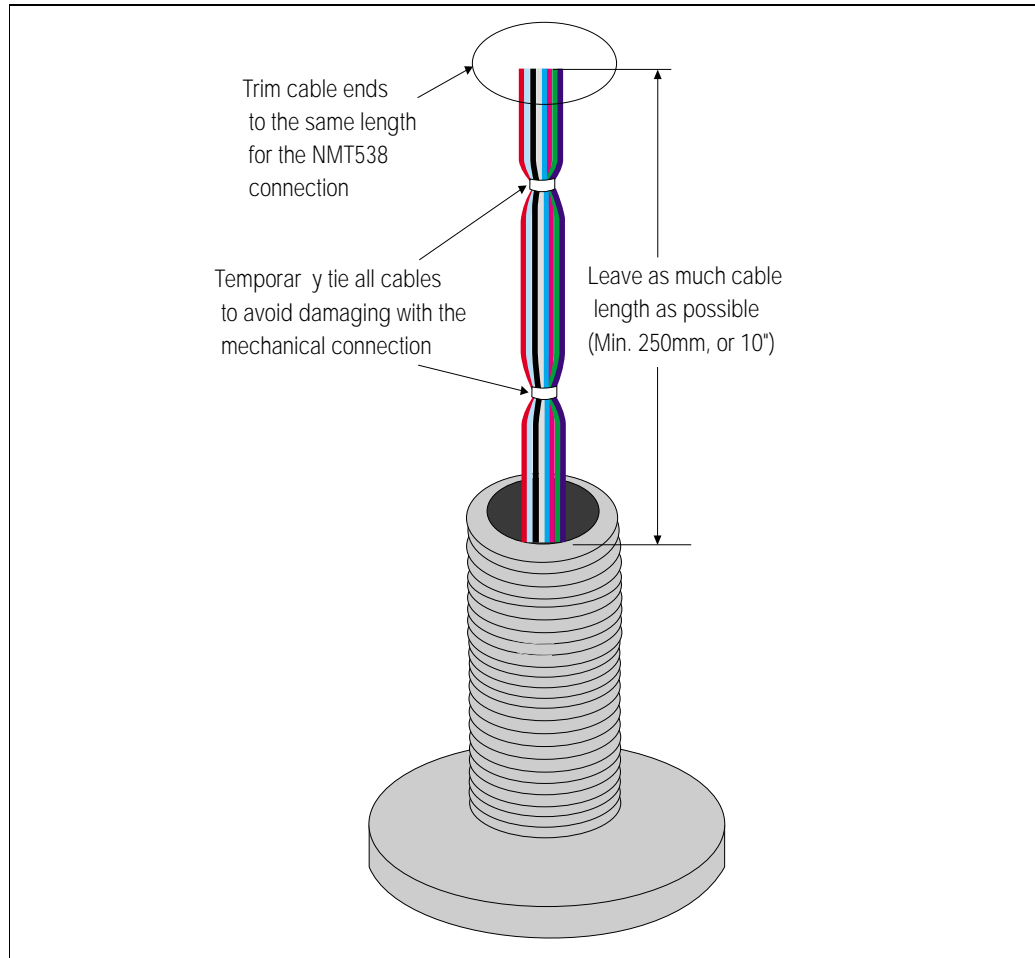
**Figure4: Preparation to the mechanical connection**

Caution!

**Caution!**

**Precaution before NMT538 mechanical installation is performed to the existing RTD probe.**

Unscrew lower NPS threaded female connector once and try to fit on the temp. RTD probe to ensure the each threaded connection can be smoothly attached.

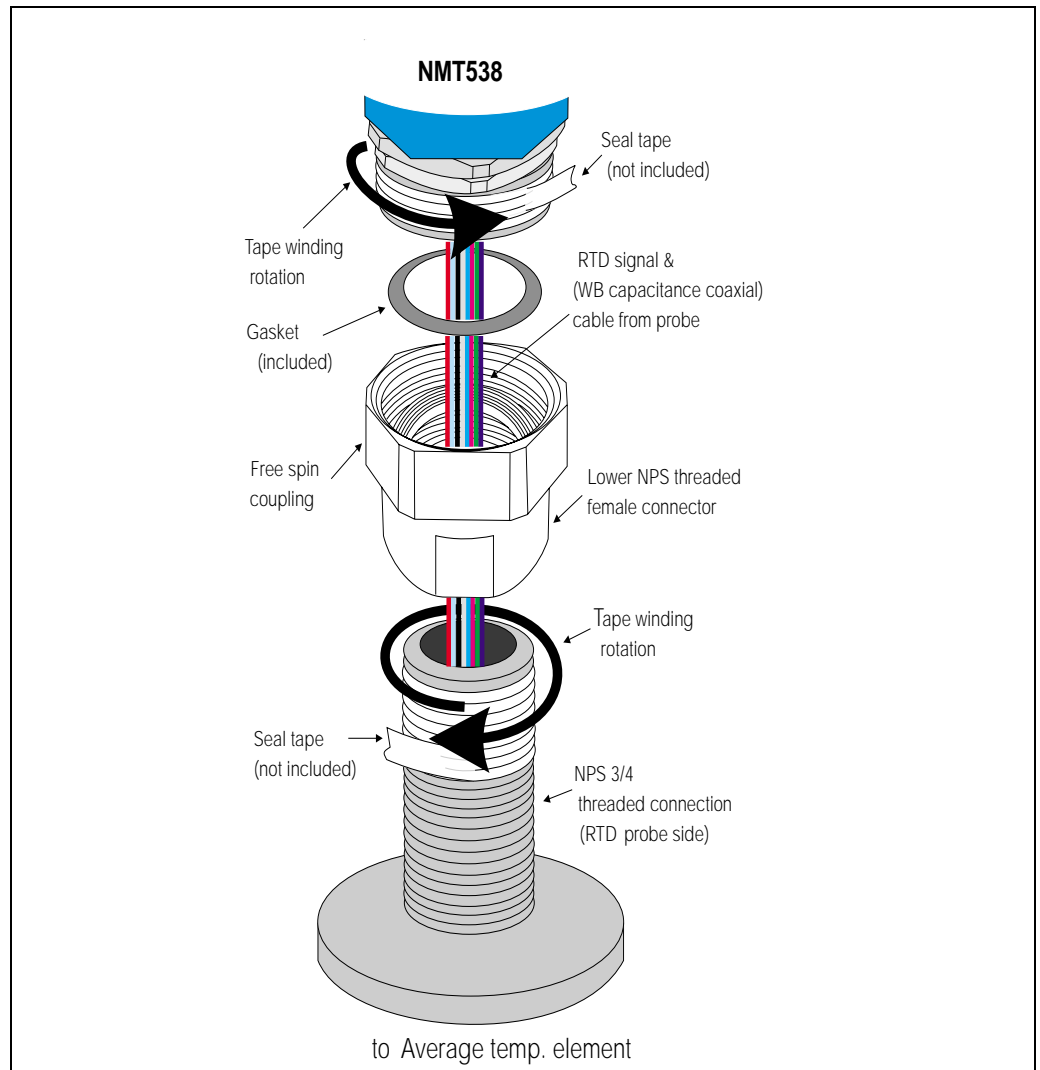
**Figure5: Threaded type connection**

1. Install lower NPS threaded female connector along with free spinning coupling onto RTD probe threaded connection until it is completely seated. Use a seal tape and rap it around on the RTD probe's threaded connection.
2. Install NMT538 housing along with included gasket in-between. Use a seal tape and rap it around on the NMT538 housing side male threaded connector, then hand tight the free spinning coupling until it stops.
3. Remove the cap cover and make sure the both side of cables have enough length to be connected freely.

**warning!**

Do not pull either side cables or apply over-tension during this procedure. Internally torn cables or loose connection can cause invalid temperature measurement.

4. After performing cable connection & positioning the face angle of NMT538, Tighten approximately 1/8th turn the free spinning coupling with a wrench from where it was hand tighten.

**3.3.2 Wiring: NMT538 to RTD probe****Temperature signal cables**

RTD cables will be directly connected to NMT538 input cables with simple cramp connectors (included). Strip each end of cable approximately 1cm (3/8") and slip into the connector, then pinch with pliers to secure the connection.

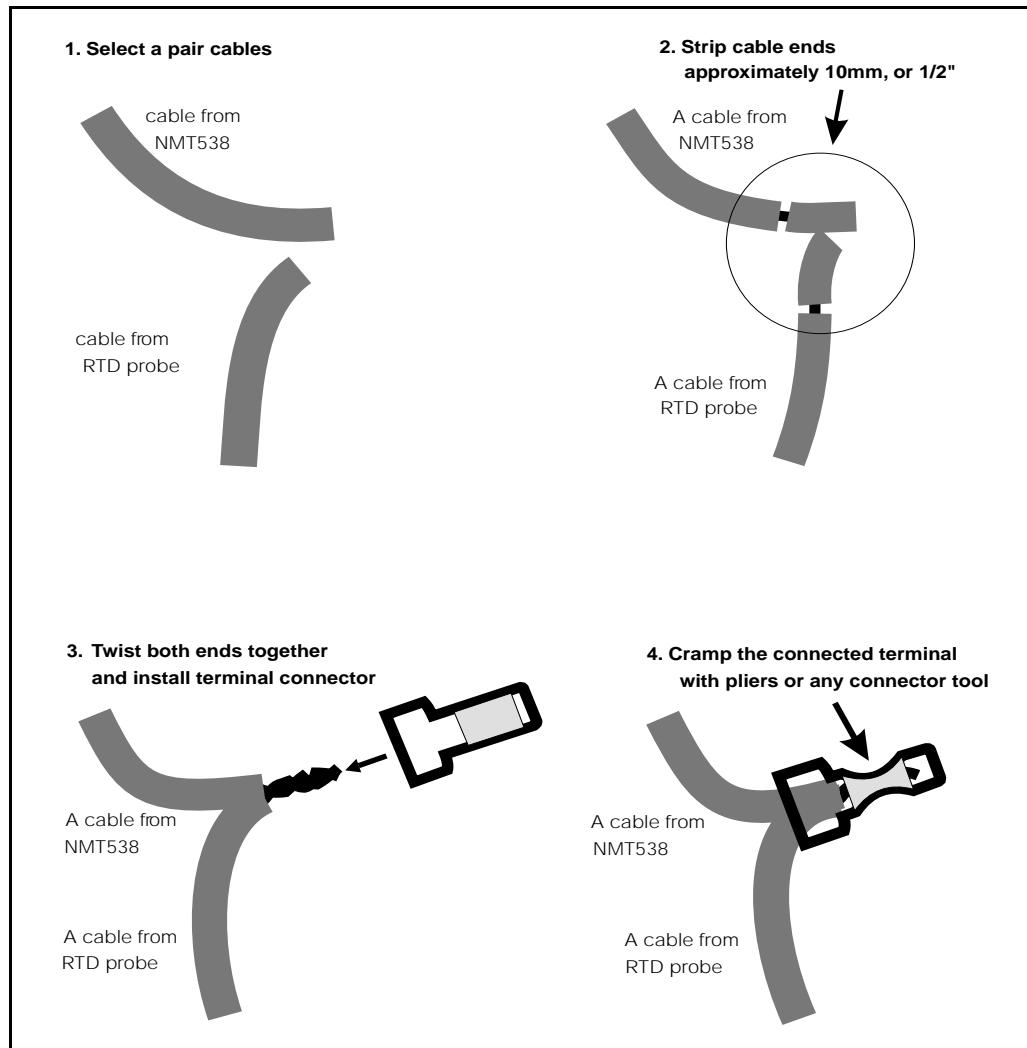
**Figure 6: Connector details**

Cabling color code is listed below.

NMT 538 cable color: the principle Based on the same as A,B,b 3 wire spot RTD cabling method.

**A: Signal wires**

No.1: brown (lowest position)

No.2: red

No.3: orange

No.4: yellow

No.5: green

No.6: blue

No.7: violet

No.8: gray

No.9: white

No.10: pink

No.11: brown / black

No.12: red / black

No.13: orange / black

No.14: yellow / black

No.15: green / black

No.16: blue / black

**B: Common wires**

B0: gray / black

B1: violet / black

b: white / black

**Diagram 1: NMT538 with Whessoe 1700 & Varec 9909**  
 Standard NMT538 to average probe connection

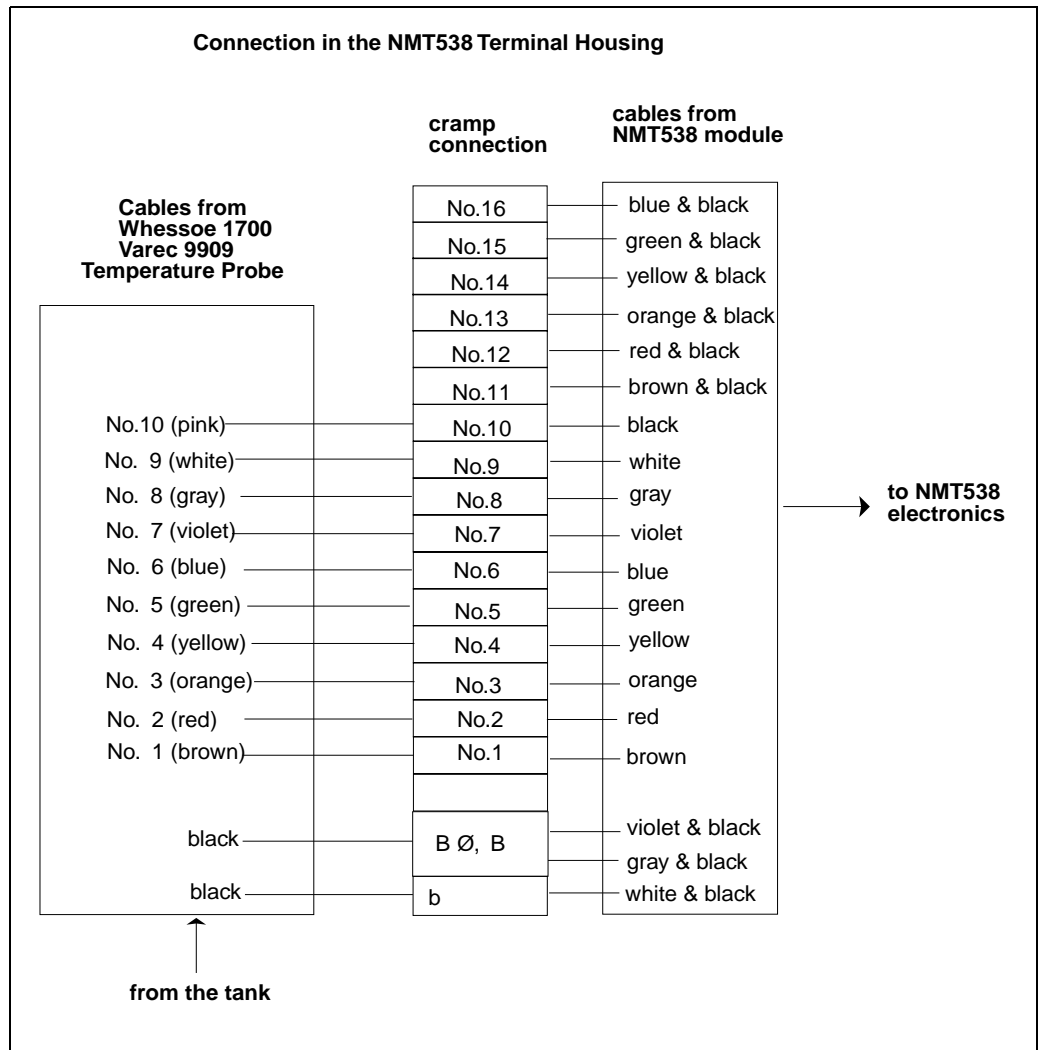

**Caution!**

Some RTD probes are equipped with additional bottom and vapor spot bulb besides average temp element. Unless a probe has these spot elements, connect brown to brown cables, red to red cables according to diagram 2. Do not skip using brown (No. 1 element) on the NMT538 side input cables. Not connected to #1 brown wire on NMT538 input will cause open circuit error (displaying 359°C) constantly.

**Diagram 2:NMT538 with Weed Beacon MWR type with Water Bottom sensor**

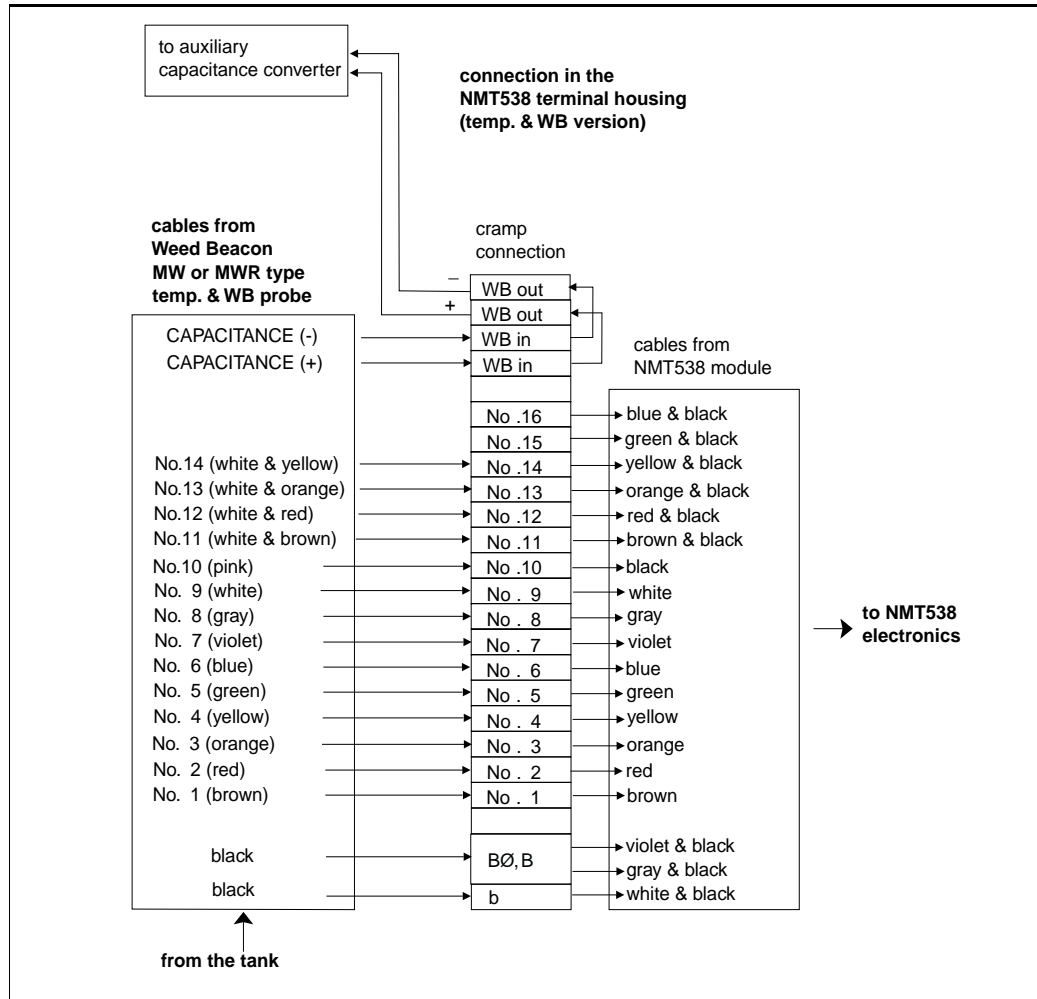

**caution!**

RTD probe side cables color may differ from diagram above. Note the connection and cable color combination during disassembling previous RTD temperature converter. This will prevent faulty element to converter connection.

Uneven cable length can influence the precise temperature calculation to be inaccurate result. Trim cable end to the even length as much as possible in case of uneven cabling condition presents at the RTD probe side cables.

**Coaxial cable for capacitance signal to auxiliary converter**

NMT538 temp. + WB version allows accessibility of coaxial cable (Water Bottom capacitance signal) from the auxiliary capacitance to HART converter (DREXELBROOK and others). The sensor cable from WB probe and converter cable through cable outlet can meet within NMT538 terminal housing or sensor cable can directly exit from cable outlet. Some WB capacitance sensor might have additional ground wire. Please route this wire to the existing CV converter accordingly without interruption inside of the NMT 538 housing.



**Diagram 3: NMT538 with Varec 9909 with bottom & vapor spot temperature**

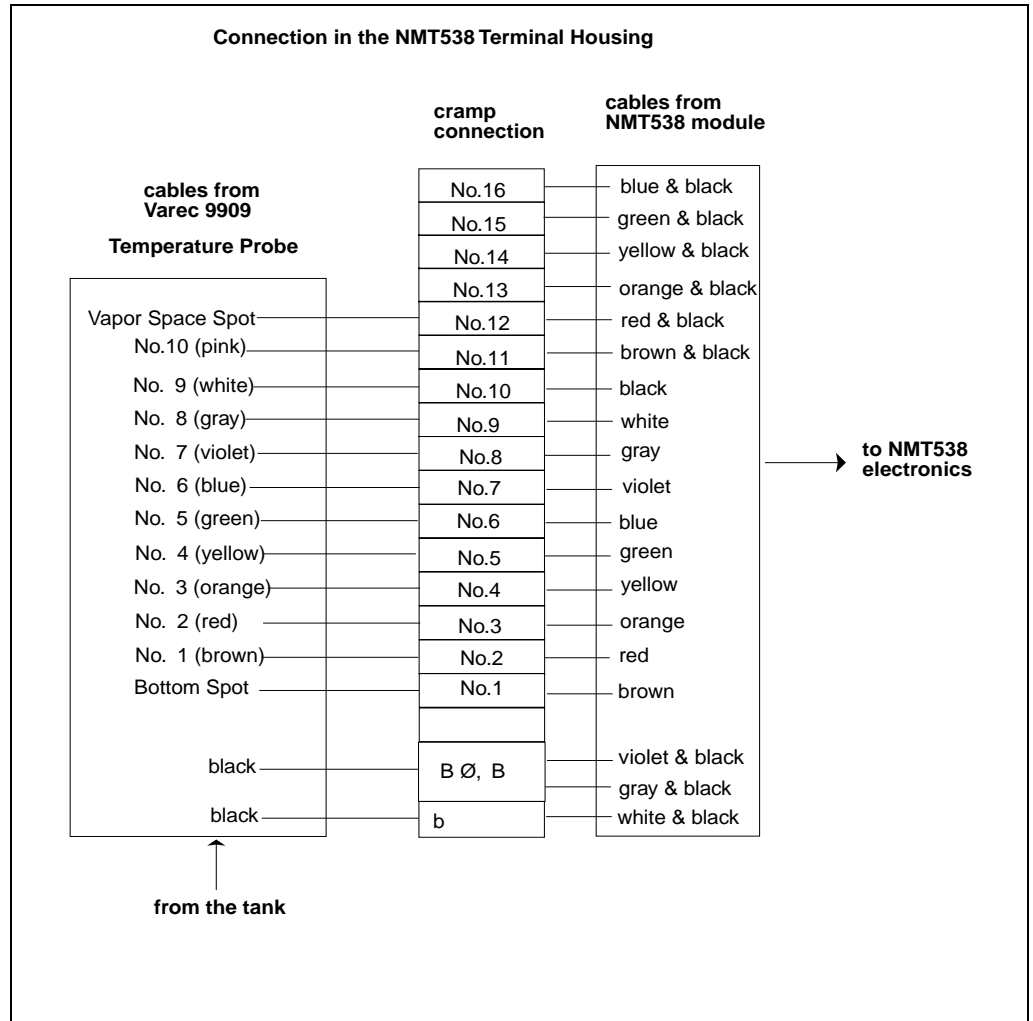

Note!

**Note!**

Since NMT538 is capable of accepting up to 16 elements for average temperature calculation, the bottom & vapor spot elements can be used to expand its measuring range. In this case, the bottom spot can be used as the #1 lowest position element for the connection to the brown wire from the NMT538. If the average elements have already 16 input, ignore connecting neither the bottom nor vapor spot element.

### 3.4 HART line cabling

NMT538 is a HART slave instrument. that requires power supply for the device operation and communication signal on the same 2 cables.

**Figure 7:NMT 538 terminal board**

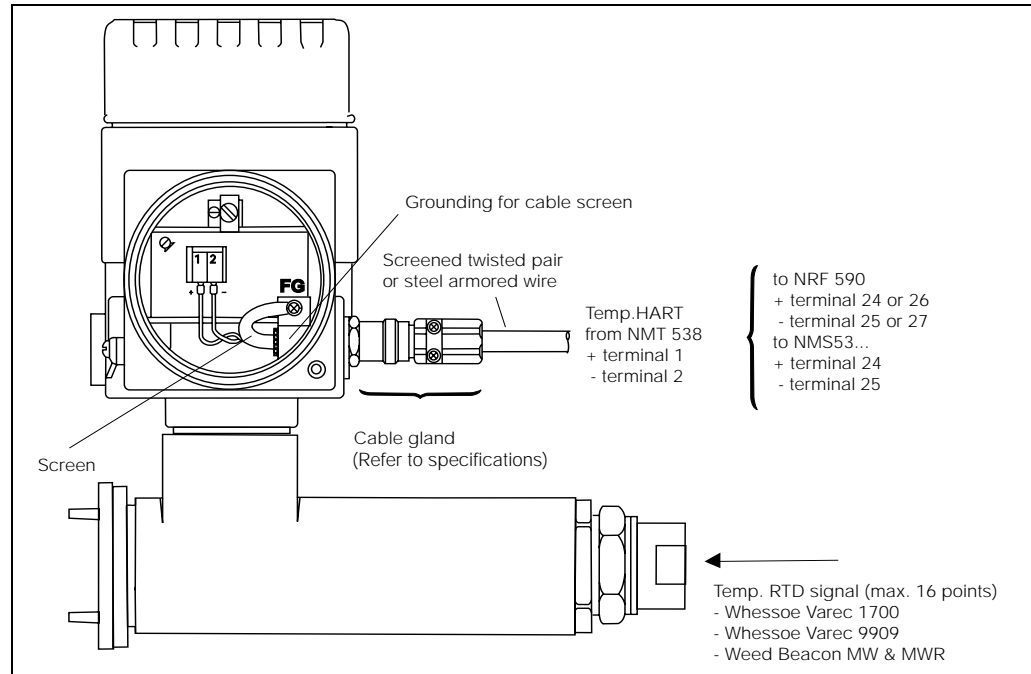

Required DC voltage for NMT538 operation is minimum 16 to maximum 30 volt. With the connection to the Proservo NMS53x, normally supply DC24V  $\pm$ 10% to the NMT538. The Tank side monitor NRF590 can normally supply DC16 $\pm$ 1V on the IS HART loop. Both the NMT538 and host instrument recognizes 0.5mA current shift as the trigger of data transmission. I.e, NMT538 normally consumes 9.0mA at temperature measurement only. The current consumption decreases to approximately 8.5mA while NMT538 is receiving command from the host gauge on the HART line. On the other hand, the current consumption increases to approximately 9.5mA while NMT538 is sending data to the host gauge as a response to the previous command.



#### **Warning!**

Before opening the cover of the Prothermo NMT538 for maintenance, switch off the power supply of the Proservo NMS53x or the Tank side monitor NRF590. Either of these 2 instruments normally are the host gauge to supply DC voltage on the IS HART line to the NMT538.

#### **3.4.1 Protection from line noise**

The following precautions are required to rule out any malfunction by line noise.

- The minimum conductor size for the HART transmission distance up to 1500m should be used 0.51mm diameter (#24 AWG) shield twisted pair cable and 0.81mm diameter (#20AWG) for longer distance.
- Use appropriate cable size reference to the conditions described below chart 1.

**Chart 1: Typical cable capacitance & distance for 1.02mm (#18 AWG) shield twisted pair**

NO. Network Devices	Cable Capacitance - pf / m (pf / ft)			
	65 pf / m (20 pf / ft)	95 pf / m (30 pf / ft)	160 pf / m (50 / pf / ft)	225 pf / m (70 pf / ft)
Cable length - meters (feet)				
1	2763 m (9000 ft)	2000 m (6500 ft)	1292 m (4200 ft)	985 m (3200 ft)
5	2462 m (8000 ft)	1815 m (5900 ft)	1138 m (3700 ft)	892 m (2900 ft)
10	2154 m (7000 ft)	1600 m (5200 ft)	1015 m (3300 ft)	769 m (2500 ft)
15	1846 m (6000 ft)	1415 m (4600 ft)	892 m (2900 ft)	708 m (2300 ft)

- If you use an unshielded wire, then equip it with a conduit pipe.
- Connect the cable screen to the frame ground.

**3.4.2 Connection to the Proservo NMS53x**

**Figure 8: Terminal connection on the Proservo NMS**

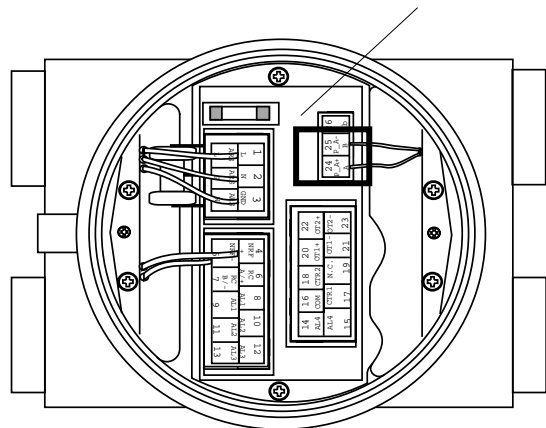
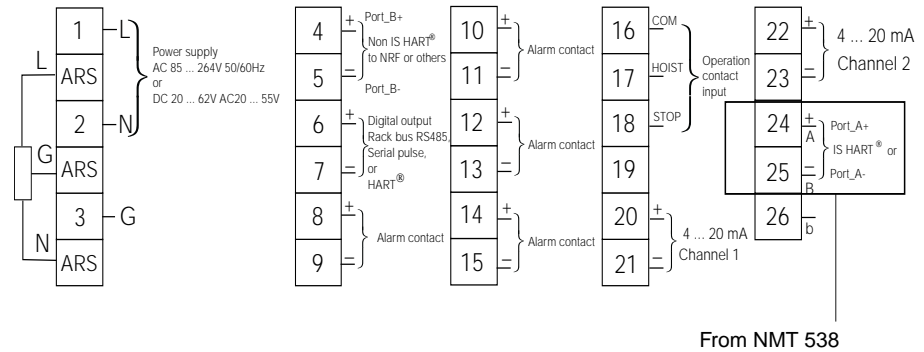

**Tank sensors**

The Proservo NMS53x can interface up to 4 HART sensors. All HART sensors are connected to one HART multi-drop communication loop internally. In order to separate IS and non-IS HART sensory connection, 2 pairs of HART terminals are equipped on the Proservo NMS53x. The NMT538 can be connected only on terminals 24(+) & 25(-) where the IS HART module is installed.



**Caution!**

NMT538 HART connection can be only allowed when the Proservo NMS53x is equipped with the intrinsically safe HART input module. The connection is not allowed when the built in spot temperature input is selected on the Proservo NMS.

**3.4.3 Connection to the Tank side monitor NRF590**

**Figure 9: Terminal connection on the tank side monitor NRF590**

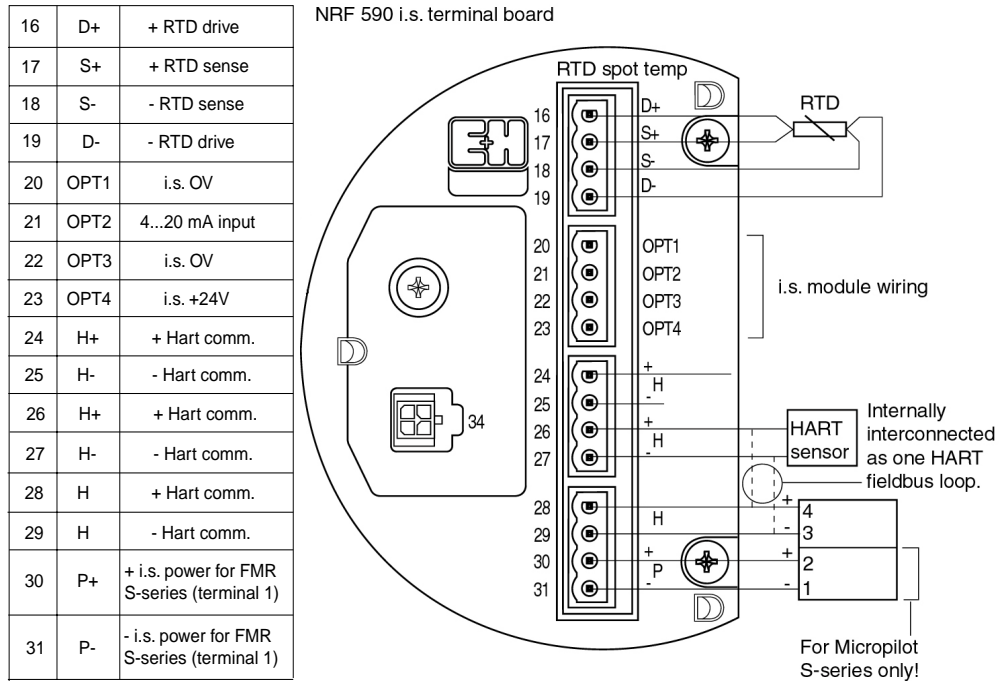

**Tank sensors**

The Tank side monitor NRF590 can interface up to 6 IS HART sensors. All HART sensors are connected to one HART multi-drop communication loop. To keep the wiring simple, 3 interconnected terminal pairs are available; however, 2 pairs of terminals, 24(+) 25(-) & 26(+) 27(-), are available for the NMT538 connection since terminals 28(+) 29(-) are reserved for the Micropilot S FMR 53x HART connection.

## 4. Operation Principle

### 4.1 High Accuracy Converter

The Prothermo NMT538 temperature signal converter is designed to fit on existing foreign RTD average temperature probe to Endress +Hauser HART compatible intelligent average temperature measurement device. The RTD average temp. probe may consist of Cu90, Cu100, PtCu100, & Pt100 multi-spot and/or multi-resistance element. The Prothermo NMT538 is capable of converting various RTD resistance input to intrinsically safe IS HART signal output. The liquid and gas phase average temperature are determined based on liquid level data that is provided by the Proservo NMS53x or FMR Micro pilot series radar gauge through Tank side monitor NRF590. Maximum up to 16 individual input can be arranged with either equal or unequal spaced element intervals are selected. Also the additional WB connection feature allows the NMT 538 to engage to the foreign water interface measurement probe with average temperature probe like Weed beacon MW & MWR type, then provide accessibility of auxiliary capacitance converter.

**Figure 10: Operating principle of NMT 538**

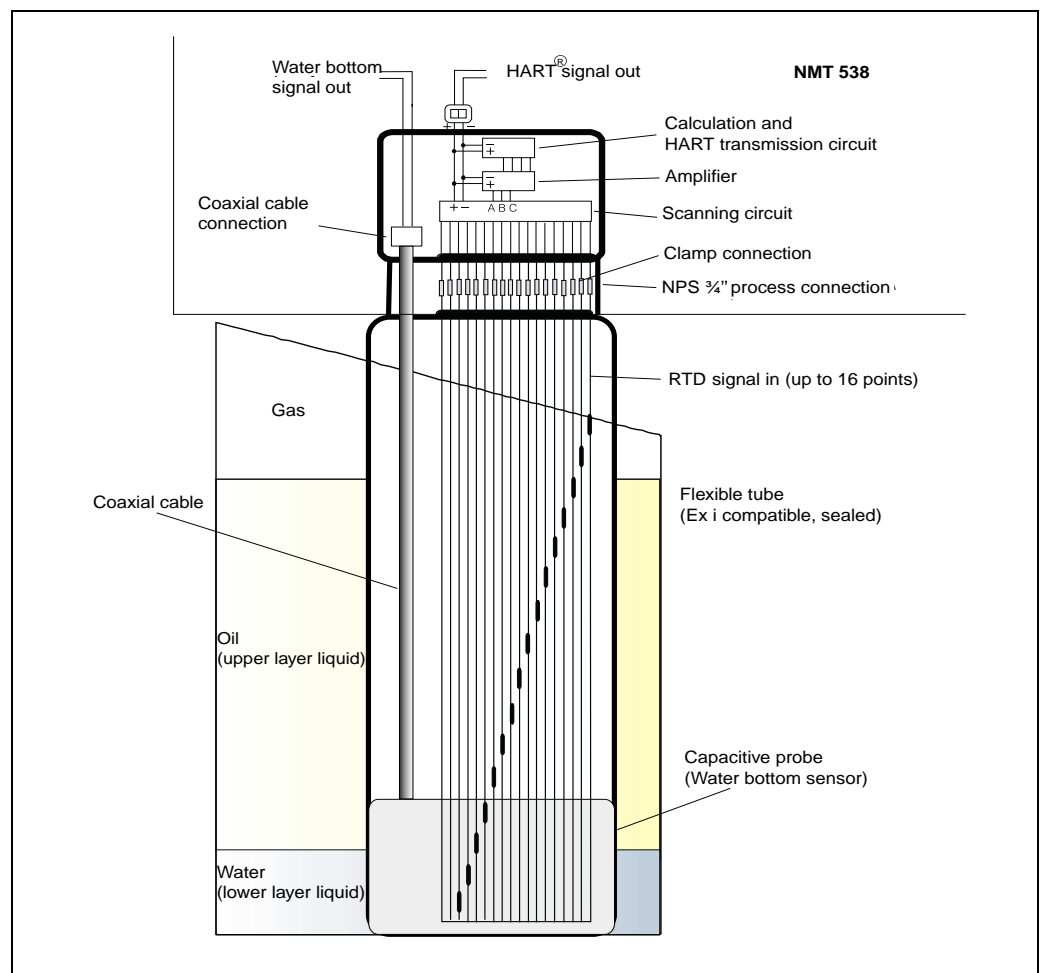

## 4.2 Temperature calculation

The NMT538 is able to calculate two separate (upper gas/ vapor layer and lower liquid layer) average temperatures described below.

### Typical calculation procedure with multi-spot element

Figure 11: Typical multi-spot element layout

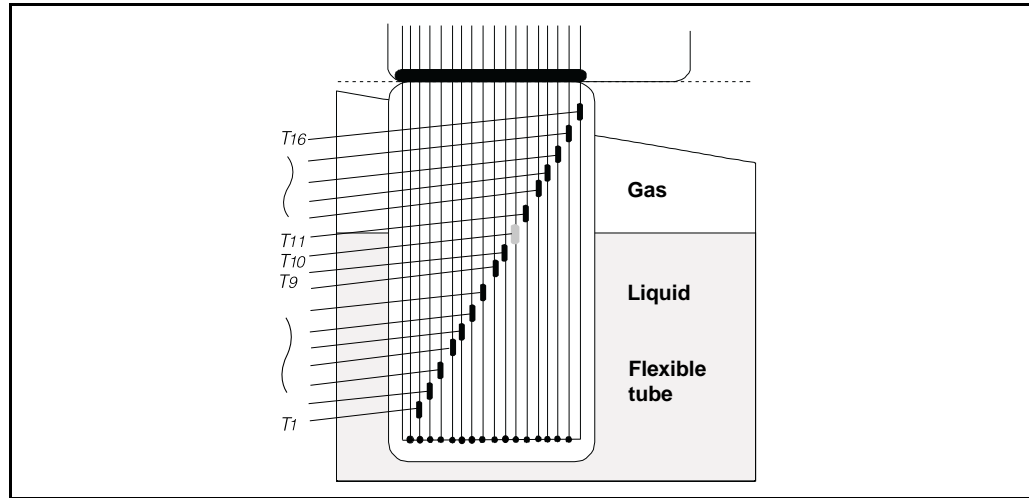

- T1, T2... T16 represent temperature data of multi-spot elements
- The element T10 is considered exactly positioning at the liquid level; therefore it is not included neither liquid nor gas average calculation based on terminology of Liquid & Gas offset.

### 4.2.1 Calculation of average temperature in the liquid layer

#### Tav, liquid Formula

$$T_{av, liq} = \frac{1}{9} \sum_{i=1}^9 T_i$$



Caution!

#### Caution! Liquid offset level

Elements to be included in liquid average calculation should be submerged 300mm below liquid surface at the default setting. Please contact with Endress + Hauser in case of changing "Liquid offset level".

### 4.2.2 Calculation of average temperature in the gas / vapor layer

#### Tav, gas formula

$$T_{av, gas} = \frac{1}{6} \sum_{i=11}^{16} T_i$$



Caution!

#### Caution! Gas offset level

Elements to be included in gas / vapor average calculation should be positioned 300mm above liquid surface at the default setting. Please contact with Endress + Hauser in case of changing "Gas offset level".

#### Canceling defected elements (pending function)

The NMT538 primarily sends out error message to the host gauge regardless of liquid level in case of the defected element or/and cable present during the operation. The operator can command the NMT538 to cancel defected elements to be out of calculation purposely by limiting gas/vapor average calculation disabled.

## 5 Operation with the Proservo NMS53x

The NMT538 basically requires the host gauge to command & initialize all regarding functionality since it is the HART slave & data display free instrument. The NMT538's operation procedure, data acquisition method, and availability of function are depending on which host gauge is connected to.

### 5.1 NMT538 operation with the Proservo NMS53x

Most of NMT538 functions are controlled & configured from the Proservo NMS53x matrix operation. The communication between the NMT538 & Proservo NMS53x is predetermined with specific polling address and protocol environment; therefore, the minimum initial set up would be required in order to start up the gauge operation.

#### 5.1.1 Home position display

The Proservo NMS53x displays several data at the "Home Position" includes the average liquid temperature data.

**Figure 12: Home Position display**

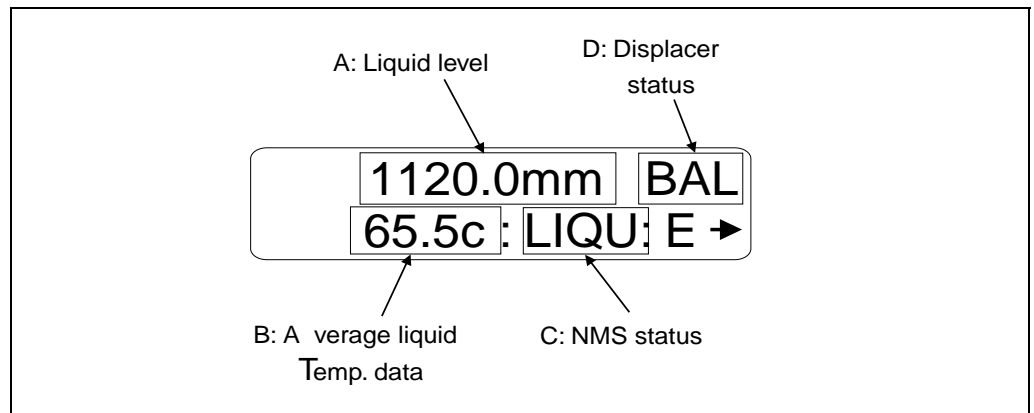

A: Liquid level, displays the last measured liquid level if the Proservo is in other operation.

B: Average liquid temperature, displays latest liquid average temperature.

C: NMS gauge status: displays type of the Proservo operation.

D: NMS displacer status: displays the status of displacer.



Note!

#### Note!

The Proservo NMS53x continuously scans and update the temperature data that transmits from the NMT538 approximately every 2 seconds per 1 matrix data during the normal operation. However, it takes approximately 3 minutes to display all NMT related data right after turning the power supply from the NMS53x.

#### 5.1.2 Optical key (touch control) operation

The operational structure of both the Proservo NMS53x & NMT538 are based on Endress + Hauser matrix concept. The Proservo NMS53x utilizes 3 infrared key (non-mechanical switch), namely E, -, +, for operation and configuration of all connected sensors includes the Proservo NMS53x itself by accessing each matrix.

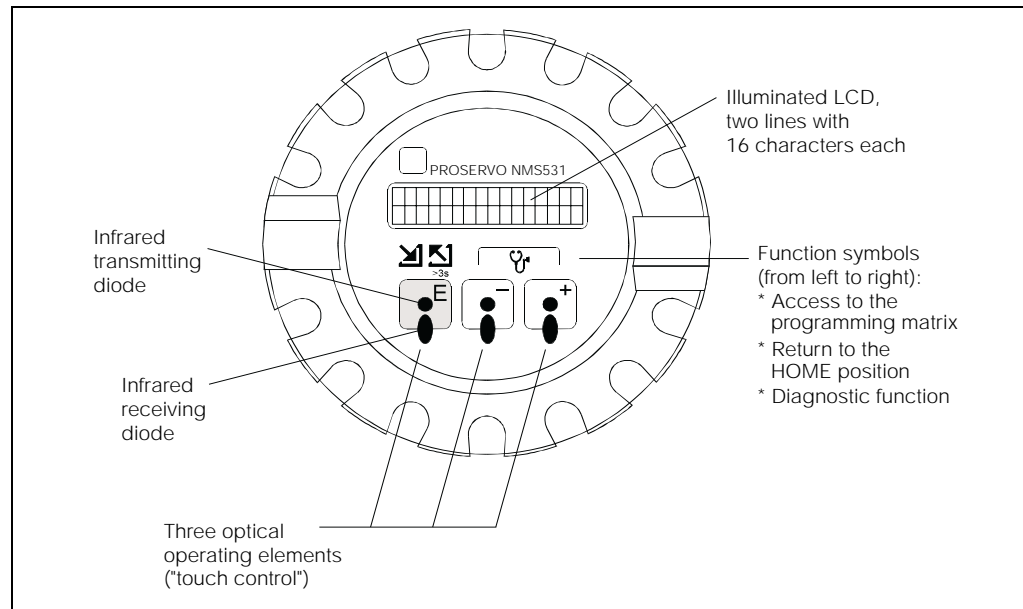
**Figure 13: NMS53x display module**

Note!

**Note!**

The LCD will return to the Home position if no key is touched for more than 10 min. Digits are incremented or decremented by + or - respectively. If you touch + or - continuously, then the minimum digit will change first. After one cycle of the minimum, the second minimum will change. After one cycle of the second follows the third minimum, and so on. If you take your finger from the touch control, then the procedure will start again from the minimum digit. (Analogy of mechanical counter)

**5.1.3 Access code**

The purpose of the access code is to secure the installed data. There are three security levels for the functions of the Proservo NMS53x.

**Access code 0 (or no value entered): no security level**

**Access code 50: security level for operator**

**Access code 51: security level for engineer**

**Access code 777 special code for HART IS switch function**

Based on the choice of access code, displaying matrix and operational functionality are also variable.



**QOC1:Quick operation guide for setting an access code**

LCD display	Procedure	Remark
1120.0mm BAL 65.5c : LIQU: E→		Home position display
	Hold "E" key for more than 3sec.	
MEASURED VALUE 1 >GROUP SELECT<: E→		Now you are in the G0 Static matrix
	Enter "+" key 3 times	
MORE FUNCTION >GROUP SELECT<: E→		Note! If you missed "MORE FUNCTION" matrix, use "-" key to reverse.
	Enter "E" key several times until "ACCESS CODE" will appear on the display.	
0 ACCESS CODE		If you missed "ACCESS CODE" matrix, keep entering with "E" till next cycle.
	Use "+" or "-" to set desired access code (50, 51, 777)	
51 ACCESS CODE		Other than 50, 51, or 777, display will reply "EDITING BLOCKED", correct code must be entered.
	Enter "E" to confirm, Access code is now acquired.	
EDITING ENABLED		Access code confirmed
	Then, Enter "E" once to return to "MORE FUNCTION" in Static matrix	
MORE FUNCTION >GROUP SELECT<: E→		Now, it is ready for further configuration

**5.1.4 Type of the Programming Matrix group**

The row 0...3 of the programming matrix are called "Static Matrix". Its functionality is to display and allow programming of mainly measured value (primary variables) and basic operation of the Proservo NMS53x and NMT538.

The row 4...9 exist on 9 different pages called as "Dynamic Matrix". These matrix groups are labeled as follows.

G1: CALIBRATION

G2: DEVICE DATA

G3: SERVICE

G4: TEMPERATURE

G5: HART DEVICE (1)

G6: HART DEVICE (2)

G7: ADJUST SENSOR

G8: TANK PROFILE (NMS software ver. 4.25 only)

G9: INTERFACE PROFILE (NMS software ver. 4.25 only)

**5.1.5 Configuring the NMT538 on the matrix of Proservo NMS53x**

To display NMT538 data and configure detailed parameters, the communication between these 2 instruments must be initially established.

**QOG 2: Configuring NMT538 on the matrix**

LCD display	Procedure	Remark
MORE FUNCTION >GROUP SELECT<: E→	"E" key once to enter the selection of Dynamic matrix (G1 to G9)	Note! Start at G0 Static Matrix, V4 "MORE FUNCTION"
CALIBRATION MATRIX OF →	Enter with "+" key twice, going to "SERVICE" matrix	Normally, G1: CALIBRATION matrix to start
SERVICE MATRIX OF →	Enter "E" key several times until "MORE FUNCTION" appears again	
MORE FUNCTION >GROUP SELECT<: E→	Enter "+" key 3 times to display "SYSTEM DATA", "E" key to confirm	Now you are in the G3 "SERVICE" matrix
SYSTEM DATA >GROUP SELECT<: E→	Enter "E" key 3 times to display "CONNECTION NMT"	
OFF CONNECTION NMT →	Use "+" or "-" key to select temp. device "AVERAGE"	Note! OFF: no temp. device selected SPOT: connection to 3 wire spot AVERAGE: connection to NMT
AVERAGE CONNECTION NMT	Enter "E" to confirm, then enter "E" several times until "MORE FUNCTION" appears	At the "CONNECTION NMT", AVERAGE must be chosen in order to display NMT configuration matrix group G4 "TEMPERATURE"
MORE FUNCTION >GROUP SELECT<: E→	Move on to the next parameter setting at G4 "TEMPERATURE" matrix	

This procedure must be completed; other wise, the Proservo will not recognize the connection of NMT538. The G4 "TEMPERATURE" matrix will be shown only this NMS53x to NMT538 communication is established on the matrix configuration.

**5.1.6 Setting parameter on the matrix**

The connected temp. element data must be input as an initial parameter setting to operate NMT538 properly.



Note!

**Note!**

The access code 51 will be required for further parameter settings

**QOG 3 Initial parameter setting of NMT538**

LCD display	Procedure	Remark
MORE FUNCTION >GROUP SELECT<: E→	"E" key once to enter the selection of Dynamic matrix (G1 to G9)	Caution!! NMT538 must be configured at the NMS53x matrix GVH 362 "CONNECTION NMT" prior to perform parameter setting
SERVICE MATRIX OF	Enter with "+" or "-" key, going to "TEMPERATURE" matrix	
TEMPERATURE MATRIX OF	Enter "E" key several times until "MORE FUNCTION" appears again	
MORE FUNCTION >GROUP SELECT<: E→	Enter "+" key 5 times to display "SET DATA NMT"	Now you are in the G4 "TEMPERATURE" matrix
SET DATA NMT >GROUP SELECT<: E→	Enter "+" key 3 times to display "TOTAL NO ELEMENT"	
16 TOTAL NO ELEMENT	Enter desired element number with "+" or "-" keys (ie,10 in this case) then, "E" to confirm	Default setting would be 16 (max. available number)
10 TOTAL NO ELEMENT	Enter "E" key twice, go to "KIND OF INTERVAL"	
EQUAL KIND OF INTERVAL	Use "+" or "-" key to select "EQUAL" or "UNEQUAL", then "E" to confirm. Enter "E" key several times to exit "SET DATA NMT" row.	Note! Choice of "UNEQUAL" allows specific element position setting "EQUAL" automatically establish each element position by setting "BOTTOM POINT" & "ELEMENT INTERVAL"



Note!

**Note!**

The choice of "EQUAL" or "UNEQUAL" element interval will determine the rest of following parameter settings.

**QOG 4 Equal element interval setting**

LCD display	Procedure	Remark
EQUAL KIND OF INTERVAL	After confirming "EQUAL" element interval, enter "E" key once, go to "BOTTOM POINT"	
500mm BOTTOM POINT	Enter with "+" or "-" key to set desired lowest element position	Note! Default setting of "BOTTOM POINT" is 500mm,
750mm BOTTOM POINT	"E" to confirm, and enter "E" again to switch matrix to "ELEMENT INTERVAL"	The element connected to NMT538 input brown wire (#1) will be controlled by this "BOTTOM POINT" setting.
2000mm ELEMENT INTERVAL	Enter with "+" or "-" key to set desired "ELEMENT INTERVAL"	Note! Default setting of "ELEMENT INTERVAL" is 2000mm
1200mm ELEMENT INTERVAL	Enter "E" key to confirm, go to additional parameter setting if necessary	This element interval data applies to all the elements to be equally spaced

**QOG 5 Unequal element interval setting up to 10 elements**

LCD display	Procedure	Remark
UNEQUAL KIND OF INTERVAL	"E" key once to confirm "UNEQUAL INTERVAL" then, enter "E" several times, return to "SET DATA NMT"	Choice of "UNEQUAL" allows specific element position setting
SET DATA NMT >GROUP SELECT<: E→	Enter with "+" or "-" key, going to "ELEMENT POSITION"	Note! Up to 10 element positions can be set at 10 matrix of "ELEMENT POSITION" More than 11 elements are existed, go to "NMT ADJUSTMENT"
ELEMENT POSITION >GROUP SELECT<: E→	Enter "E" key once, go to "ELEM. 1 POSITION"	
500mm ELEM. 1 POSITION	Using "+" or "-" key to enter the lowest element position	
655mm ELEM. 1 POSITION	"E" to confirm, then enter "E" to go to "ELEM. 2 POSITION. Repeat same procedure until the last element.	

**QOG 6: Unequal element interval setting more than 11 elements installed**

LCD display	Procedure	Remark
UNEQUAL KIND OF INTERVAL	"E" key once to confirm "UNEQUAL INTERVAL" then, enter "E" several times, return to "SET DATA NMT"	Choice of "UNEQUAL" allows specific element position setting
SET DATA NMT >GROUP SELECT<: E→	Enter with "+" or "-" key, going to "NMT ADJUSTMENT" matrix	Note! Up to 10 element positions can be set at 10 matrix of "ELEMENT POSITION" row."
NMT ADJUSTMENT >GROUP SELECT<: E→	Enter "E" key once, go to "SELECT POINT" then, select set number from 0 to 15 by "+" or "-" key, and "E" to confirm	Caution!! #1 element is set at "SELECT POINT 0" ; therefore, #16 element will be set at "SELECT POINT 15".
0 SELECT POINT	Enter "E" 4 times, go to "ELEMENT POSITION"	
655mm ELEMENT POSITION	Set desired element position by "+" or "-" key, then "E" to confirm. Enter "E" several times until next "SELECT POINT" appears, then set next element position. Repeat same procedure until the last element position is set.	

### 5.1.7 Additional parameter setting functions

Refer to each matrix position in G4 "TEMPERATURE" & G7 "ADJ SENSOR" matrix

#### **ZERO ADJUSTMENT GVH471: default setting 0**

The base line adjustment when the measured value need to be adjusted. i.e. Entering desired value; for example, "2" when the NMT 538 indicates 23°C in compare to the reference thermometer value indicates 25°C.

#### **AVERAGING GVH478: default setting 2**

Sampling number of average calculation. Can be increased up to 16 times depending on instability of data acquisition by noise factor and others.

#### **PREAMBLE NUMBER GVH483: default setting 5**

Based on the HART protocol definition, selectable up to 16 preamble numbers, depending on the condition of local HART communication.

#### **TEMP. ELEM. SHORT GVH488: default value -49.5°C (-57.1°F)**

Error display with a temp. value when an element or circuit is short. Set the desired value with "+" or "-" key, then "E" to confirm.

#### **TEMP. ELEM. OPEN GVH489: default value 359°C(679.1°F)**

Error display with a temp. value when an element or circuit is open. Set the desired value with "+" or "-" key, then "E" to confirm

#### **OUTPUT AT ERROR GVH492: default value ON**

"ON" to display short or open circuit value (-49.5 or 359) on HOME position and both average temp. data (liquid & gas phase). Disable average calculation due to defected element or circuit exist. "OFF" to enable average calculation with last available data. The matrix of individual defected element number indicates short or open circuit information regardless.

#### **CUSTODY TRANSFER GVH493: default setting OFF**

A function to freeze set parameter of NMT538 once it is turned on. Needs to turn off when initial parameter is required to over write

#### **POLLING ADDRESS GVH494: default setting 2**

Select other address with "+" or "-" key in case of connecting to any other HART device and require changing the address.

## 5.2 The Proservo NMS53x matrix (NMT538 related matrix only)

### Matrix G0 Static matrix

### NMS53x Programming Matrix (Static Matrix)

GROUP MESSAGE	V	H									
		0	1	2	3	4	5	6	7	8	9
MEASURED VALUE 1	0	16000.00 mm MEASURED LEVEL Display	0.0 mm ULLAGE LEVEL Display	0.0 mm UPPER INTERF. LEV Display	0.0 mm MIDD. INTERF. LEV Display	0.0 mm BOTTOM LEVEL Display	1.000 g/ml UPPER DENSITY 0.000 - 3.000 Display/Set (50)	1.000 g/ml MIDDLE DENSITY 0.000 - 3.000 Display/Set (50)	1.000 g/ml DENSITY BOTTOM 0.000 - 3.000 Display/Set (50)	0.0 mm LEVEL DATA Display	OFF STATUS1 ON Display
MEASURED VALUE 2	1	0.0°C LIQUID TEMP. Display	DEV(1) Display	DEV(2) Display	0.0°C GAS TEMPERATURE Display				0 mm ZERO POINT Display	16000.0 mm SPAN Display	mm LENGTH UNIT Display
OPERATION	2	STOP OPERATION 16000 See below operation commands Select (50)	STOP OPERATING STATUS See below status table Display	UNBALANCED BALANCING STATUS Display		LEVEL OPERAT.BY NRF Display	LEVEL OPERAT.BY HOST Display			411 DEVICE ID	8424 SOFTWARE VERSION
MORE FUNCTION	3	CALIBRATION MATRIX OF Select			98 627 8:21:00 CALENDER Current data Display	NO ALARM ALARM CONTACT 0 Current data Display	NO ALARM LA 0 0 0 0 Current data Display	NO ERROR DIAGNOSTIC CO 0 Current data Display	MPU:START ACT 98 627 752 0 0 Current data Display		0 ACCESS CODE 0 , 50, 51, 777 Set

Matrix G3 Service matrix

NMS53x Programming Matrix (Dynamic Matrix, Service: G3)

GROUP MESSAGE	H V	0	1	2	3	4	5	6	7	8	9
MEAS.WIRE & DRUM	4	300.00 mm WIRE DRUM CIRC. 0 - 999.9 Set (51)	1.4 g / 10m WIRE WEIGHT 0 - 999.9 Set (51)	255.0 g DISPLACER WEIGH 0 - 999.9 Set (51)	145.0 mL DISPLACER VOLUM 0 - 999.9 Set (51)	60 mL BALANCE VOLUME 0 - 999.9 Set (51)	1.0 mL VOLUME TOLERANCE 0 - 99.9 Set (51)		20 X 100 mS DELAY 0 - 99 Set (51)	0.00 mm/m DRUM CORRECTION 0 - 99.00 Set (51)	0 count DISPL.HUNT.COUNT 0 - 99 Set (51)
GAUGE DATA	5			OFF NON HYSTER. MOD ON Select (51)	OFF HI. ACCURACY MOD ON Select (51)	0 s BI. ACCR. OPE. TIME 0 - 600 Set (51)	50 mm HI. ACC. DISP. UP 0 - 300 Set (51)	Current Data GAUGE TEMP. Display (51)			
SYSTEM DATA	6	LOCAL : MASTER SENSOR DATA REMOTED COM. ON SOFTWARE = 04.20 HARDWARE=TCB04 GEAR 1:36 NOT OVERSPILL	OFF CONNECTION NRF CONTACT 1 CONTACT 2 Select (51)	OFF CONNECTION NMT SPOT TEMP. AVERAGE TEMP. Select (51)							OFF SOFT RESET ON Select (51)
SERVICE	7	0.0 g MEASURED WEIGHT Display	OFF RELE. OVER TENS ON Select (51)	OFF DRUM SETTING ON Select (51)	OFF WEIGHT CALIBR. ON Select (51)					70 mm DISPL. REFERENCE Set (51)	0.0 g ZERO ADJ. WEIGHT Set (51)
SENSOR VALUE	8	Sa=21000:A=21000 Sb=11000:B=11000 Display (51)									
SENSOR DATA	9					0 0 0.0g WT.COUNT CAL A Display (51)	0 0 0.0g WT.COUNT CAL B Display (51)				



Matrix G4 Temperature matrix

NMS53x Programming Matrix (Dynamic Matrix, Temperature: G4)

GROUP MESSAGE	V	H									
		0	1	2	3	4	5	6	7	8	9
TEMPERATURE DATA	4	xx °C LIQUID TEMP. Current data Display (51)	zz °C GAS TEMPERATURE Current data Display (51)	aaaa.a mm MEASURED LEVEL Current data Display (51)	VH00 LEV.DATA SELECT VH08 Select (51)				0.0 °C REFERENCE ZERO Current data Display (51)		150.0 °C REFERENCE 150 Current data Display (51)
ELEMENT TEMP.	5	aa.a °C TEMP. NO.1 Current data Display (51)	bb.b °C TEMP. NO.2 Current data Display (51)	cc.c °C TEMP. NO.3 Current data Display (51)	dd.d °C TEMP. NO.4 Current data Display (51)	ee.e °C TEMP. NO.5 Current data Display (51)	ff.f °C TEMP. NO.6 Current data Display (51)	gg.g °C TEMP. NO.7 Current data Display (51)	hh.h °C TEMP. NO.8 Current data Display (51)	hh.h °C TEMP. NO.9 Current data Display (51)	jj.j °C TEMP. NO.10 Current data Display (51)
ELEMENT POSITION	6	xxx.x mm ELEM.1 POSITION Current data Display (51)	xxx.x mm ELEM.2 POSITION Current data Display (51)	xxx.x mm ELEM.3 POSITION Current data Display (51)	xxx.x mm ELEM.4 POSITION Current data Display (51)	xxx.x mm ELEM.5 POSITION Current data Display (51)	xxx.x mm ELEM.6 POSITION Current data Display (51)	xxx.x mm ELEM.7 POSITION Current data Display (51)	xxx.x mm ELEM.8 POSITION Current data Display (51)	xxx.x mm ELEM.9 POSITION Current data Display (51)	xxx.x mm ELEM.10 POSITION Current data Display (51)
NMT ADJUSTMENT	7	0 SELECT POINT 0 - 15 Selectable SELECT POINT + 1 = ELEMENT No. Set (51)	x.x °C ZERO ADJUST Set (51)		xx.x °C ELEMENT TEMP Current data Display (51)	xxx.x mm ELEMENT POSITION Current data Display (51)				2 AVERAGE TIME Set (51)	
SET DATA NMT	8	0 DIAGNOSTIC Display (51)		16 TOTAL NO.ELEMEN 2 - 16 Set (51)	5 PREAMBLE NUMBER 1 - 16 Set (51)		EQUAL KIND OF INTERVAL UNEQUAL Select (51)	500.0 mm BOTTOM POINT 0.0 mm to 500.0 mm valuable Set (51)	2000.0 mm ELEMENT INTERVAL Set (51)	-49.5 °C TEMP.ELEM.SHORT Display (51)	359.0 °C TEMP.ELEM. OPEN Display (51)
DEVICE DATA NMT	9	xxxxxx INSTRUMENT CODE Display (51)	LAST DIAGNOSTIC Display (51)	OUTPUT AT ERROR Select (51)	OFF CUSTODY TRANSFER ON Display (51)	2 POLLING ADDRESS Display (51)	17 MANUFACTURE ID Display (51)	6 SOFTWARE VERSION Display (51)	2 HARDWARE VERSION Display (51)		183 DEVICE TYPE CODE 181 Display (51)

Matrix G7 Adjust Sensor matrix

**NMS53x Programming Matrix (Dynamic Matrix, ADJ. SENSOR: G7)**

GROUP MESSAGE	V	H	0	1	2	3	4	5	6	7	8	9
ADJ. SENSOR	4		ADJ. A ZERO	ADJ. A SPAN	ADJ. B ZERO	ADJ. B SPAN						
HART ERROR RATE	5		0.00% ERR. RATE NMF	0.00% ER. RATE NMT	0.00% ERR. RATE DEV(1)	0.00% ERR. RATE DEV(2)						
UNIT	6											
HART LINE	7		TERMINAL PORT B NMT TERMINAL PORT A  Select (777)	TERMINAL PORT B HART DEVICE (1) TERMINAL PORT A  Select (777)	TERMINAL PORT B HART DEVICE (2) TERMINAL PORT A  Select (777)							
INTERFACE ADJUST	8		0.3 mL VOL.TOL.FOR I/F 0 - 99.9 mL  Set (51)	150 BRAKE RATE 0 - 255  Set (51)	15 BALANCE COUNT 0 - 255  Set (51)	0.0 mm IF1 OFFSET 0 - 9999.9 mm  Set (51)	0.0 mm IF2 OFFSET 0 - 9999.9 mm  Set (51)					
NONE	9											

### 5.3 Description of the programming matrix

The description of following matrix design & contents are based on accessibility from the Proservo NMS53x. Further detailed operation is required, please refer to the operation manual of the Proservo NMS53x.

Matrix group	Function group	Item	Access code	Short description	Default vaule	Set Select Display	Possible settings, selections, or displays	Index No, GVH
STATIC MATRIX (This word is not shown)	MEASURED VALUE 2	LIQUID TEMP.	0	If a temperature bulb is connected, then this position shows the measured liquid temperature. Otherwise the LCD will be blank.	0.0 °C	Display	-49.9 ... 249.9 °C	010
		GAS TEMPERATURE	0	If a temperature bulb is connected, then this position shows the measured gas temperature.	0.0 °C	Display	-49.9 ... 249.9 °C	013
	MORE FUNCTION	MATRIX OF	0	Selection of the dynamic matrix of the programming matrix	CALIBRATION	Select	CALIBRATION DEVICE DATA SERVICE TEMPERATURE HART DEVICE (1) HART DEVICE (2) ADJ. SENSOR	030
		(Calendar)	0	Calendar and clock without daylight saving system. NOT TRANSFERRED BY RACKBUS.	Japanese local time	Display	e.g. 1 410 19:10:41 Year Month Day HH:MM:SS	033
		DIAGNOSTIC CO	0	Self diagnosis at the moment		Display	Error message (refer to attached table)	036
		(Erroneous Message)	0	Previous alarm with message. Only the last alarm code is transmitted by Rackbus.	(Erroneous Date)	Display	Error message (refer to attached table)	037
		ACCESS CODE	0	Access code for programming (see Sec. 10.4)	0	Set	0 ... 9999	039
SERVICE	SYSTEM DATA	CONNECTION NMT	51	Connection of the Prothermo NMT538	OFF	Select	OFF SPOT (three wire RTD input) Average (NMT538)	362

Matrix group	Function group	Item	Access code	Short description	Default vaule	Set Select Display	Possible settings, selections, or displays	Index No, GVH
TEMPERATURE  Note! The whole matrix is available when NMT is connected and SPOT or AVERAGE temperature element is selected.	TEMPERATURE DATA	LIQUID TEMP.	51	Current average liquid temperature.		Display	-49.9 ... 249.9 °C	440
		GAS TEMPERATURE	51	Current average gas temperature.		Display	-49.9 ... 249.9 °C	441
		MEASURED LEVEL	51	Level from the Proservo. The level data are used for the averaging of liquid and gas temperatures.		Display	0.0 ... 99999 mm	442
		LEV. DATA SELECT	51	Possible to select a measured level data from matrix pos. GVH=000 (displacer position), or GVH=008 (level data after balanced).	VH00	Select	VH00 VH08	443
		REFERENCE ZERO	51	Display of reference resistance on printed circuit board that corresponds to 0 °C.	0.0 °C	Display		447
		REFERENCE JPT150	51	Display of reference resistance on printed circuit board that corresponds to JPT 150 °C.	152.5 °C	Display		448
		REFERENCE 150	51	Display of reference resistance on printed circuit board that corresponds to 150 °C.	150.0 °C	Display		449
	ELEMENT TEMP.  Note! For elements with numbers beyond the value set at GVH=482, the LCD will show 358.0 °C	TEMP NO. 1	51	Temperature of element No. 1 (deepest point)		Display	-49.9 ... 249.9 °C	450
		TEMP NO. 2	51	Temperature of element No. 2		Display	-49.9 ... 249.9 °C	451
		TEMP NO. 3	51	Temperature of element No. 3		Display	-49.9 ... 249.9 °C	452
		TEMP NO. 4	51	Temperature of element No. 4		Display	-49.9 ... 249.9 °C	453
		TEMP NO. 5	51	Temperature of element No. 5		Display	-49.9 ... 249.9 °C	454
		TEMP NO. 6	51	Temperature of element No. 6		Display	-49.9 ... 249.9 °C	455
		TEMP NO. 7	51	Temperature of element No. 7		Display	-49.9 ... 249.9 °C	456
		TEMP NO. 8	51	Temperature of element No. 8		Display	-49.9 ... 249.9 °C	457
		TEMP NO. 9	51	Temperature of element No. 9		Display	-49.9 ... 249.9 °C	458
		TEMP NO. 10	51	Temperature of element No. 10		Display	-49.9 ... 249.9 °C	459

Matrix group	Function group	Item	Access code	Short description	Default vaule	Set Select Display	Possible settings, selections, or displays	Index No, GVH
TEMPERATURE  Note! The whole matrix is available when NMT is connected and SPOT or AVERAGE temperature element is selected.	ELEMENT POSITION  Note! The LCD shows the element position measured from the tank bottom (for previously set elements only).	ELEM. 1 POSITION	51	Position of temperature element No. 1 (deepest point), namely Bottom Element.	500mm	Display	0 ... 99999 mm	460
		ELEM. 2 POSITON	51	Position of temperature element No.2	2500mm	Display	0 ... 99999 mm	461
		ELEM. 3 POSITON	51	Position of temperature element No.3	4500mm	Display	0 ... 99999 mm	462
		ELEM. 4 POSITON	51	Position of temperature element No.4	6500mm	Display	0 ... 99999 mm	463
		ELEM. 5 POSITON	51	Position of temperature element No.5	8500mm	Display	0 ... 99999 mm	464
		ELEM. 6 POSITON	51	Position of temperature element No.6	10500mm	Display	0 ... 99999 mm	465
		ELEM. 7 POSITON	51	Position of temperature element No.7	12500mm	Display	0 ... 99999 mm	466
		ELEM. 8 POSITON	51	Position of temperature element No.8	14500mm	Display	0 ... 99999 mm	467
		ELEM. 9 POSITON	51	Position of temperature element No.9	16500mm	Display	0 ... 99999 mm	468
		ELEM. 10 POSITION	51	Position of temperature element No.10	18500mm	Display	0 ... 99999 mm	469
	NMT ADJUSTMENT	SELECT POINT	51	Element number selection for reading element temperature and position from element No. 11 to No. 16.	0	Display	0 (element No.1) 10 (element No.11)	470
		ZERO ADJUSTMENT	51	Zero adjustment		Set	-20.0 ... 20.0 °C	471
		ELEMENT TEMP.	51	Element temperature selected at "SELECT POINT"		Display	-49.9 ... 249.9 °C	473
		ELEMENT POSITION	51	Element position selected at "SELECT POINT"		Display	0 ... 99999 mm	474
		AVERAGING	51	Sampling coefficient for averaging of data. If there is a high degree of instability due to noise or other factors, increase ist value.	2	Set	1 ... 10	478

Matrix group	Function group	Item	Access code	Short description	Default vaule	Set Select Display	Possible settings, selections, or displays	Index No, GVH
TEMPERATURE Note! The whole matrix is available when NMT is connected and SPOT or AVERAGE temperature element is selected.	NMT SET DATA	DIAGNOSTIC CODE	51	Display of current diagnostic code.	0	Display	0 ... 255	480
		TOTAL NO. ELEMENT	51	The total number of elements that are mounted in the flexible tube. This number is determined in accordance with the specifications provided when the order of the device is placed.	16	Set	a ... A HEX	482
		PREAMBLE NUMBER	51	Display of preambles for HART® protocol.	5	Display	2 ... 14 HEX	483
		KIND OF INTERVAL	51	Temperature element intervals. - Equal intervals: 0 - Unequal intervals: 1 If 1 is chosen, then set the element position on matrix from GVH=460 to GVH=469.	0	Set	0 or 1	485
		BOTTOM POINT	51	Height of bottom point. Only available when equal intervals are selected.	500mm	Set	0.0 ... 99999.9 mm	486
		ELEMENT INTERVAL	51	Interval between temperature elements. Only available when equal intervals are selected.	2000mm	Set	0.0 99999.9 mm	487
		TEM. AT SHORT ELE.	51	Temperature indication when element is shorted. This value is sent to the Proservo only when the error output is "ON" at GVH=492. When the error output is "OFF", the average temperature is sent to the Proservo.	-49.5 °C	Set		488
		TEM. AT OPEN ELE.	51	Temperature indication when element is opened. This value is sent to the Proservo only when the error output is "ON" at GVH=492. When the error output is "OFF", the average temperature is sent to the Proservo.	359.0 °C	Set		489

Matrix group	Function group	Item	Access code	Short description	Default value	Set Select Display	Possible settings, selections, or displays	Index No, GVH
TEMPERATURE  Note! The whole matrix is available when NMT is connected and SPOT or AVERAGE temperature element is selected.	NMT DEVICE DATA	INSTRUMENT CODE	51	Display of the hardware unit number		Display		490
		LAST DIAGNOSTIC	51	Display of the last error message. If there was no error, then the LCD will be blank.		Display		491
		OUTPUT AT ERROR	51	Selection of output and indication in case of short circuit or open circuit elements at GVH=488 or 498	1	Select	0: OFF 1: ON	492
		CUSODY TRANSFER	51	Custody transfer mode. If this mode is switched on, then the LCD will show on.	OFF	Select	OFF ON	493
		POLLING ADDRESS	51	Assignment of an address to Prothermo NMT538 when this and other HART <sup>®</sup> devices are multi-dropped on the HART <sup>®</sup> communication line. Polling address 2 is fixed by Proservo firmware.	2	Set	1 ... F (Total 16 address can be set.)	494
		MANUFACTURER ID	51	Identification number of the manufacturer (17 for Endress+Hauser).	17	Display		495
		SOFTWARE VERSION	51	Software version of the Prothermo NMT538.	5.0	Display	4.0 or higher	496
		HARDWARE VERSION	51	Hardware version of the Prothermo NMT538.	1.4	Display	1.4 or higher	497
		DEVICE TYPE CODE	51	Display of the device type code (181 for the Prothermo NMT538)	181	Display		499
ADJ. SENSOR	HART LINE	NMT	777	Assignment of Prothermo NMT538 with IS HART or Non-IS HART connection. - TERMINAL PORT B: Non-IS HART connection - TERMINAL PORT A: IS HART connection	TERMINAL PORT B	Set	TERMINAL PORT B TERMINAL PORT A	770

## 6 Operation with the Tank Side Monitor NRF590

The wiring between the Prothermo NMT538 to NRF590, refer to the section 3.4 HART line cabling prior to the actual operation through NRF590.

### 6.1 Initial NMT538 configuration before connect to NRF590



Caution!

#### Caution!

Nature of the Prothermo NMT538 indicates various acceptability of foreign RTD average probe connection for converting the E+H standard HART communication device.

Following terms must be clarified and preliminary configured by auxiliary HART communication device; for example, generic HART communicator, service tool like ToF (Time of Flight) tool, or the Proservo NMS.

-Number of element: NMT538 is normally delivered with 16 element numbers (maximum connection). If fewer element numbers will be connected without proper set up, the average temperature data will be unavailable due to the presence of element with no response. (Display of error message 358.5°C)

-Lowest element position: The default lowest element position of NMT538 is 500mm (19.7").

-Element interval: Based on the configuration of connected average temperature probe, each element position must be determined by interval between elements. Default setting is 2000mm (78.7") equally spaced interval.

### 6.2 Additional adjustment factors

The Prothermo NMT538 has its own programming matrix that only E+H Sakura factory device can access to. Following terms should be consulted with E+H personnel at ordering of the NMT538.

-Liquid offset level: In order to calculate liquid average temperature, only elements submerged below 300mm (11.8") from the measured liquid level are involved in calculation. This offset value can be entered only at the factory set up.

-Gas offset level: Just like liquid offset level, the gas phase average temperature calculation includes the element that locates at least 300mm above measured liquid surface. The default setting (300mm) can be only altered at the factory facility.



Note!

#### Note!

All of above initial configuration can be executed from ToF (Time of Flight) service tool with NMT538 Device Description implemented.

### 6.3 NMT 538 operation from NRF 590 Tank Side Monitor

The NRF 590 Tank Side Monitor already has pre installed device menu for the NMT 538 as well as FMR series radar level gauge. As soon as necessary hardware installation (includes device setting & wiring) is completed, the NMT 538 is activated by the NRF 590's power supply on the IS HART loop. The device configuration from the NRF 590 to the NMT 538 is limited to the following items.

- Preamble Cmd (07c46)
- Tag (07c48)
- Temperature units (07c56)
- Level units (07c75)
- Address (07w42)



Note!

#### Note!

As long as necessary initial configurations are completed, NMT 538 shall be able to start measuring temperature inside the tank as well as calculating both liquid & gas average temperature based on liquid level acquired from the FMR series radar level gauge.

Please refer to the NRF 590 Tank Side Monitor operation manual for the data displaying functionality.



## 7 Configuration from ToF (Time of Flight) tool

In order to access NMT 538 parameters directly through ToF (Time of Flight) tool, least below listed items are required.

1. NMT 538 DD (Device Description) for ToF tool.
2. E+H HART modem with 232C connector
3. ToF installed computer (Do not use conventional Lap Top computer at hazardous are. Be sure to use intrinsically safe computer if on site configuration is required.)

### 7.1 NMT 538 DD installation in ToF tool environment

1. Within the NMT 538 DD CD package, copy entire "NMT538\_V010200\_HART" folder into ToF Tool ; Dev DB folder.
2. Open "NMT538\_V010200\_HART" folder and select "enu".
3. Within "enu" folder, Right click on "NMT538\_dd.enu.dll", and click on "Resister COM Server".
4. Installation of NMT 538 DD will automatically start, then click "Yes" to finish installation.

### 7.2 NMT 538 Configuration on ToF tool

#### Note!

Hook up the E+H HART modem in the NMT 538 connected HART loop prior to ToF tool activation on your computer.

In case the host gauge to be the NRF 590 Tank Side Monitor, set "HART SCANNER" menu to "DISABLE" on NRF 590. Due to the characteristic of multi drop HART loop, presence of two HART master devices may cause configuration problem.

#### 7.2.1 ToF tool activation

Start up the ToF tool and select "SCAN-BUS" to seek available HART device on the loop. Since NMT 538 has no own operational power supply, it has to be connected NMS 53x Proservo or NRF 590 Tank Side Monitor to provide proper operation DC voltage.

Once the NMT 538 is recognized on the HART loop, device list on the bottom of the screen should indicate the presence of NMT 538. Then double click on the NMT 538.

#### 7.2.2 NMT 538 DD structure

NMT 538 DD is structured in 4 separate groups.

##### Temperature: data display only

All of parameters are display only. Reading of various temperature related data form the NMT 538.

##### NMT Set Data: data display & parameter configuration

Most of these parameters are named and positioned based on the Proservo NMS's matrix numbers. Please refer to the section 5.6.1 "Setting Parameter on the Matrix and section 5.6.1 "Additional Parameter Setting".

##### NMT Device Data: device data display

Most of parameters are display of NMT's own device information except "tag no." and "assembly number". These two are the only parameters you can configure in this group.

##### Position: data display & parameter configuration

Display of element position from element 1 to 10. If "Even Interval" is chosen and "Bottom Element Position" is configured in NMT Set Data group, no parameter set would be necessary. If "Uneven Interval" is chosen, this is the group to set element position (only element 1 to 10).

#### Note!

You have to go back to NMT Set Data and select "Calibration Select" to choose element number and "Position X" to enter element position for element 11 to 16 (1 to 10 can be configured same way in this method).

### 7.3 NMT 538 default value

NMT 538 is configured in most common parameters at factory set up. Normally you do not have to set all of parameters. Please refer to the ToF tool instruction within the screen. Common parameters are,

Bottom Element Position: 500mm

Element Interval: equal

Number of Element: 16 elements

Please refer to the section 5.1.7 "Additional Parameter Setting" to confirm rest of default value.

## 8 Error code

NMT538 has functionality of self diagnostic error detection for both electrical & mechanical conditions. NMT538 also transmits those conditions to various error displays and message to inform connected host gauge.



Note!

### Note!

Most of error message remains even after correcting or fixing problems. Reset the software to default setting (device configuration data will be remained) or turning the power supply once is necessary

### Error display

NMT538 has several numeric error status indication.

#### **-49,5°C (-57.1°F): Element short**

Element or wiring circuit on particular element number is electrically or physically short. Can be shown either individual and / or average temp. matrix depending on error display set up.

#### **358°C (676.4°F): Unsuitable element position**

358°C will be shown on the liquid average temp. display when the liquid level is below the lowest element position. On the other hand, 358°C is also shown on gas / vapor average temp. display when all elements are completely submerged in the liquid.

#### **358.5°C (677.3°F): Invalid element data reading**

A display when operator seeks for non-existing element data. i.e. #12 element data on only 10 elements are connected. This is different from 359°C Element open. The entered value of configured element number must meet the actual number of connected elements.

#### **359°C (678.2°F): Element open**

Element or wiring circuit on particular element number is electrically or physically open. Can be shown either individual and / or average temp.

#### **359.5 °C (679.1°F): Communication error**

HART Communication error, caused by device to device local HART connection. Only NMS uses this error display mainly for remote communication data transmission.

**Chart 6: Error message**

Message	Cause	Remedy
TEMP.COM.OPEN	Common line for elements break.	Check the common line for elements. Consult E+H Service for replacement of the temperature sensor.
TEMP.COM.SHORT	Common line for elements short circuit.	Check the common line for elements. Consult E+H Service for replacement of the temperature sensor.
ELEM.X OPEN X = 1...16	No. x element (or line) break.	Check the element. Measure the resistance by attaching a Digital Multimeter rod to the connector. (*)
ELEM. XSHORT X = 1...16	No. X element (or line) short circuit.	Check the element. Measure the resistance by attaching a Digital Multimeter rod to the connector. (*)

(\*) Never use an analog-type tester, which would allow too much electric current to flow to the measuring element when determining the resistance. The current should be limited to 1 mA or less during such a test.

Message	Cause	Remedy
ELEM 0 RANGE OVER	The reading of the reference resistance (0 C) on the printed circuit board is out of tolerance.	The circuit board should be replaced. Contact E+H service.
TEM BELOW RANGE	The measured temperature is below the set range.	Measure the temperature in the tank. If it is significantly different from the indicated Prothermo setting, check the temperature-element resistance.
TEM OVER RANGET	The measured temperature is above the set range.	Measure the temperature in the tank. If it is significantly different from the indicated Prothermo setting, check the temperature-element resistance.
BELOWBOT. POINT	The level data are below the lowest (bottom) element.	The reading gives only the average gas temperature.

## 9 Appendix

Characteristic of NMT538 compatible average temp. element. NMT538 is able to convert 4 different RTD type signals to Endress + Hauser compatible intrinsically safe HART signal.



Caution!

### Caution!

Following 4 different tables describe resistance signal conversion characteristic of each NMT 538 software. Mismatched software & element will cause the temperature reading as well as conversion error. Please consult with E+H personnel when the existing probe has elements that can not be determined.

#### Pt100ohm element resistance & temperature characteristic

°C	-15	-10	-5	0	5	10	15	20	25	30	35	40
°F	5	14	23	32	41	50	59	68	77	86	95	104
Resistance (ohm)	94.12	96.09	98.04	100.00	101.95	103.90	105.85	107.79	109.73	111.67	113.61	115.54

°C	45	50	55	60	65	70	75	80	85	90	95	100
°F	113	122	131	140	149	158	167	176	185	194	203	212
Resistance (ohm)	117.47	119.40	121.32	123.24	125.16	127.07	128.98	130.89	132.80	134.70	136.60	138.50

#### Cu90ohm element resistance & temperature characteristic

°C	-15	-10	-5	0	5	10	15	20	25	30	35	40
°F	5	14	23	32	41	50	59	68	77	86	95	104
Resistance (ohm)	80.96	86.67	84.76	90.48	92.38	94.29	96.19	98.10	100.00	101.91	103.81	105.71

°C	45	50	55	60	65	70	75	80	85	90	95	100
°F	113	122	131	140	149	158	167	176	185	194	203	212
Resistance (ohm)	107.62	109.52	111.43	113.33	115.24	117.14	119.05	120.95	122.85	124.76	126.66	128.57

#### Cu100ohm element resistance & temperature characteristics

°C	-15	-10	-5	0	5	10	15	20	25	30	35	40
°F	5	14	23	32	41	50	59	68	77	86	95	104
Resistance (ohm)	84.48	86.42	88.36	90.3	92.24	94.18	96.12	98.06	100	101.94	103.88	105.82

°C	45	50	55	60	65	70	75	80	85	90	95	100
°F	113	122	131	140	149	158	167	176	185	194	203	212
Resistance (ohm)	107.76	109.7	111.64	113.58	115.52	117.45	119.39	121.33	123.27	125.21	127.15	129.09

#### PtCu100ohm element resistance & temperature characteristic

°C	-15	-10	-5	0	5	10	15	20	25	30	35	40
°F	5	14	23	32	41	50	59	68	77	86	95	104
Resistance (ohm)	94.41	96.33	98.25	100.17	102.05	103.98	105.90	107.83	109.75	111.68	113.60	115.53

°C	45	50	55	60	65	70	75	80	85	90	95	100
°F	113	122	131	140	149	158	167	176	185	194	203	212
Resistance (ohm)	117.45	119.38	121.30	123.23	125.15	127.08	129.00	130.93	132.85	134.78	136.58	138.50

---

Sakura Endress Co., Ltd  
862-1 Mitsukunugi,  
Sakaigawamura,  
Higashi-Yamanashigun,  
Yamanashiken 406-0846  
Japan

Phone: ++81-55-266-4964  
Fax: ++81-55-266-4969  
<http://www.endress.com>

Endress+Hauser  
Systems & Gauging

